

 **DUT**
DURBAN
UNIVERSITY OF
TECHNOLOGY

 **FACULTY OF
ENGINEERING
& THE BUILT
ENVIRONMENT**

2019 HANDBOOK ELECTRONIC AND COMPUTER ENGINEERING

HANDBOOK FOR 2019

FACULTY OF ENGINEERING AND THE BUILT ENVIRONMENT

**DEPARTMENT of
ELECTRONIC AND COMPUTER ENGINEERING**

DEPARTMENTAL VISION AND MISSION STATEMENT

VISION

To be known for excellence in producing electronic and computer engineering professionals who use engineering and technology for societal development in South Africa.

MISSION

- To produce socially responsible graduates attuned to the needs of industry, the environment and the community.
- To ensure that teaching and learning follows best practice.
- To engage in research and development activities that are responsive to national and international challenges in clearly defined areas of strength.

UNIVERSITY OF TECHNOLOGY

The objective of a University of Technology such as DUT is “to create, apply and transfer knowledge and technology of an international standard through cooperative and professional career education programmes.”

Committee of Technikon Principals (CTP) (2004), Universities of Technology in South Africa
DUT, which is a leading institute of higher learning within the Kwa-Zulu Natal (KZN) region, is committed to providing quality and current education, within the technology sector, to successful prospective learners. The university’s vision captures this with the simple phrase that reads “A preferred university for developing leadership in technology and productive citizenship.”

The qualifications on offer within the Department of Electronic and Computer Engineering have been developed to achieve the long-term strategic objectives of DUT; namely:

1. A teaching and learning environment that values and supports the university community;
2. Promoting excellence in learning and teaching, technology transfer and applied research; and
3. External engagement that promotes innovation and entrepreneurship through collaboration and partnership.

Moreover, the qualifications have been designed and structured to encourage graduates to be:

1. Socially relevant;
2. Professionally career orientated;
3. Exposed to a technologically relevant environment to ensure technological excellence; and
4. Able to carry out the notion of “lifelong learning”

TABLE OF CONTENTS	Page
General Department and Faculty Information	1
Staff	2
Instructional Programmes Offered by the Department	3
Bachelor of Engineering Technology in Electronic Engineering	4
BE1 General Information	4
BE2 Minimum Admission Requirements	7
BE3 Promotion to a Higher Level (Progression Rules)	8
BE4 Unsatisfactory Academic Progress	9
BE5 Programme Structure	9
BE6 Abridged Module Content	14
BE6 Supplementary Programmes	23
Master of Engineering (MEng)	24
ME1 General Information	24
ME2 Minimum Admission Requirements	24
ME3 Award of the Degree	24
Doctor of Engineering (DEng)	25
DE1 General Information	25
DE2 Minimum Admission Requirements	25
DE3 Award of the Degree	25
Research	26
RE1 General Information	26
RE2 Research Groups	27
National Diploma: Engineering: Electrical (Light Current)	28
EL1 General Information	28
EL2 Career Choices	28
EL3 Programme Structure	30
National Diploma: Engineering: Computer Systems	33
CS1 General Information	33
CS2 Career Choices	33
CS3 Programme Structure	35
National Diploma: Engineering: Electrical (Light Current) & Computer Systems	37
LC1 Minimum Admission Requirements	37
LC2 Selection	38
LC3 Duration of Studies	38
LC4 Award of Diploma	39
LC5 Registration	39
LC6 Student Conduct	39
LC7 Promotion to a Higher Level	39
LC8 Unsatisfactory Academic Progress	39
LC9 Semester Mark	39
LC10 Method of Assessment	40

LC11	Sub-Minimum	40
LC12	Supplementary Examinations	40
LC13	Work Integrated Learning	40
LC14	Service Departments	40
LC15	Contact Time	41
LC16	Self-Study	41
LC17	Fields of Study	41
LC18	Abridged Module Content	42

Baccalaureus Technologiae Degree: Engineering: Electrical (Light Current) 48

BT1	General Information	48
BT2	Minimum Admission Requirements	49
BT3	Duration of Studies	49
BT4	Award of Degree	49
BT5	Unsatisfactory Academic Progress	50
BT6	Semester Mark	50
BT7	Method of Assessment	50
T8	Sub-Minimum	50
BT9	Supplementary Examinations	50
BT10	Fields of Study	51
BT11	Programme Structure	51
BT12	Abridged Module Content	53

IMPORTANT NOTICE

The departmental rules in this handbook must be read in conjunction with the Durban University of Technology's General Rules contained in the current General Handbook for Students.

NOTE TO ALL REGISTERED STUDENTS

Your registration is in accordance with all current rules of the Institution. If, for whatever reason, you do not register consecutively for every year/semester of your programme, your existing registration contract with the Institution will cease. Your re-registration anytime thereafter will be at the discretion of the Institution and, if permitted, will be in accordance with the rules applicable at that time.

GENERAL DEPARTMENT AND FACULTY INFORMATION

Department of Electronic and Computer Engineering, DUT

Block S8, Level 3, Steve Biko Campus, Steve Biko Road, Durban 4001.

Postal Address: PO Box 1334 Durban, KwaZulu-Natal, RSA. 4000

Head of Department Dr S Reddy

All Departmental queries to:

Secretary	Mrs Premi Chetty
Telephone	031-373 2932
Fax	031-373 2744
Email	premi@dut.ac.za
Website	http://cs.dut.ac.za

All Faculty queries to:

Faculty Officer	Mrs N Singh
Telephone	031-373 2718
Fax	031-373 2719

Location of Faculty Office: Steve Biko Campus, S4 Level 3

Executive Dean	Prof T Andrew
Dean's Secretary	Ms P Nadar
Telephone	031-373 2762
Fax	031-373 2724

Location of
Executive Dean's Office: Steve Biko Campus, S6 Level 5

Central Applications Office (CAO)

Private Bag X06, Dalbridge 4014. Tel: 031-2684444, website: www.cao.ac.za

Engineering Council of South Africa (ECSA)

Private Bag X691, Bruma, 2026. Tel: 011-6079500, Fax: 011-6229295

Email: engineer@ecsa.co.za, website: www.ecsa.co.za

South African Institute of Measurement and Control

Tel./Fax: 011-888 8332

Email: ctr@SAIMC.org.za, website: www.saimc.org.za

South African Institute of Electrical Engineers (SAIEE)

Secretary: Ms Gill Nortier, PO Box 22222, Glenashley, 4022.

Tel/fax: 031-5725838

Email: saiee@africa.com, website: www.saiee.org.za

South African Qualifications Authority (SAQA)

Postnet Suite 248, Private Bag X06, Waterkloof, 0145.

Tel: 012-4315000 Fax: 012-4315039, website: www.saqa.org.za



DEPARTMENTAL STAFF

Head of Department:	Dr S Reddy; BSc(Eng) (UND), M.Eng (Pret), Ph.D (UCT); SMSAIEE, MIEEE
Deputy HOD:	Mr K E Moorgas; NDip (MLST), BTech (DIT), MTech (DUT); MSAIEE, Pr.Tech.Eng (ECSA)
Director:	Mr K S Moodley; NDT (MLST), MDipTech (MLST); MSAIEE
Associate Professor:	Prof B Nleya; MSc, Ph.D (SUT, St. Petersburg); SMIEEE, SMIEICE, Pr.Eng (ECSA)
Associate Director:	Mr S D MacPherson; NDT (TN), MDipTech (TN); MSAIEE, Pr.Tech.Eng (ECSA)
Senior Lecturers:	Mr G P Janse van Vuuren; NDT (TN), MDipTech(TN); SMSAIMC, Pr.Tech.Eng (ECSA) Mr A Moolla; NHD (PSE), (MLST), MDipTech (MLST) Mr B Saligram; MDipTech (MLST) Dr N Singh; BSc(Eng) (UN), MSc(Eng) (UN), MBA (UN), Ph.D (UKZN); Pr.Eng (ECSA) Dr O A Sokoya; BSc(Eng) (OAU), M.Eng (UKZN), Ph.D(UP)
Lecturers:	Mr V Beerajh; NHD (MLST), NHD (PSE) Mr M R A Bera; BSc(Eng) (UDW); MSAIEE Mr L G Budula; NDip (MLST), BTech (MLST) Mr S A K Essack; NDT (MLST), MDipTech (MLST); MSAIEE Mr P A Howells; NDip (TN), BTech (TN) Mr S Maharaj; NDip (DUT), BTech (DUT), M.Eng (DUT) Mrs A Pillay; NDip (TN), BTech (DIT), MTech (DUT) Dr N Pillay; NDip (MLS), BTech (DIT), MTech (DUT), DEng (DUT); Pr.Tech.Eng (ECSA) Mr S Sewdass; NDip (DIT), BTech (DUT), M.Eng (DUT) Mr R Sewsunker; BSc(Eng) (UKZN), MSc(Eng) (UKZN), MSc(E Eng) (WSU, USA); SAIEE, ECSA Ms N Shezi; NDip (DUT), BTech (DUT)
Senior Technicians:	Mr B Doorsamy; BTech (TUT) Mr I Haniff; BSc(Eng)(UKZN); SMSAIEE Mr P Morris; NDip (TN), BTech (DUT)
Technicians:	Mr P Hendry; NDip (MLST) Mr A Jooravan; NDip (DIT), BTech (DUT), MBA(UKZN) Mr N Ragbeer; NHD (MLST)
Senior Technical Assistants:	Mr R Ebrahim Mr N Rupnarain
Secretary:	Mrs D Chetty; NHD (MLST)

INSTRUCTIONAL PROGRAMMES OFFERED BY THE DEPARTMENT

Programmes are offered in this Department which, upon successful completion, lead to the award of the following qualifications:

Qualification	Qualification Code	SAQA NLRD Number
HEQSF		
Bachelor of Engineering Technology in Electronic Engineering	BNELCI	99514
Master of Engineering (MEng)	MNELCI	96827
Doctor of Engineering (DEng)	DNELCI	96812
NATED 151		
National Diploma: Engineering: Electrical (Light Current)	NDEL2	72228
National Diploma: Engineering: Computer Systems	NDCSY2	72227
Baccalaureus Technologiae Degree: Engineering: Electrical (Light Current)	BTELCI	72129

BACHELOR OF ENGINEERING TECHNOLOGY IN ELECTRONIC ENGINEERING [BEngTech (Electronic Engineering)]

BEI GENERAL INFORMATION

The undergraduate programme in electronic and computer engineering, which leads to the internationally accredited BEngTech degree, is designed to provide a broad foundation in electronic and computer engineering through a combination of classroom lectures, online tools and extensive hands-on technical training as well as laboratory work. The qualification prepares the student for a career in the variety of electronic and computer engineering fields as well as becoming a competent practicing engineering technologist or certificated engineer that will make a meaningful contribution to the economy and national development.

The programme will provide the student with a strong foundation in mathematics, physical sciences and the core fundamentals of engineering and blends theory, concept and application. Electronic and computer engineering finds itself at the heart of the burgeoning Industry 4.0 and merges fields such as telecommunications, control systems, embedded and intelligent systems, data analytics and machine intelligence, automation and robotics, signal and image processing, smart factories and cities, green energy, AI and the industrial IoT.

The learning programme leading to this qualification contains 428 credits with a minimum of 120 Credits at NQF level 7. The Credits are distributed to create a coherent progression of learning towards the exit level. This qualification requires a minimum of three years of academic study.

Some of the key attributes of the programme include the fostering of lifelong learnership, the need for continuous improvement, teamwork and the attainment of solid critical thinking and problem-solving skills. The BEngTech qualification will also allow for further study through articulation into the postgraduate NQF level 8 BEngTech Honours programme, to be offered at DUT, and the subsequent opportunity for masters and doctoral research.

Qualified candidates may register with the internationally affiliated Engineering Council of South Africa (ECSA) as Professional Engineering Technologists and/or Professional Certified Engineers.

Professional Engineering Technologists are characterized by the ability to apply established and newly developed engineering technology to solve broadly defined problems, develop components, systems, services and processes. They provide leadership in the application of technology in safety, health, engineering and commercially effective operations and have well-developed interpersonal skills. They work independently and responsibly, applying judgement to decisions arising in the

application of technology and health and safety considerations to problems and associated risks. Moreover, Professional Engineering Technologists have a specialized understanding of engineering sciences underlying a deep knowledge of specific technologies together with financial, commercial, legal, social and economic, health, safety and environmental matters.

Professional Certificated Engineers are characterized by the ability to apply established and newly developed engineering technology to solve broadly-defined problems, develop components, systems, services and processes in specific areas where a legal appointment is required in terms of either the Occupational Health and Safety Act, the Mines Health and Safety Act, or the Merchant Shipping Act, e.g. factories, mines and marine environments. They provide leadership in safety, health, engineering and commercially effective operations and have well-developed managerial skills. They work independently and responsibly, applying judgement to decisions arising in the application of technology and health and safety considerations to problems and associated risks. Professional Certificated Engineers have a specialized understanding of engineering sciences underlying manufacturing, marine, mining, plant and operations, together with financial, commercial, legal, socio - economic, health, safety and environmental methodologies, procedures and best practices.

The graduates of this degree will demonstrate evidence, as appropriate to their disciplines, of the following attributes:

1. Basic Proficiency and Competencies, including:
 - a. Information literacy
 - b. Communication (oral and written)
 - c. Numeracy
 - d. Technology applications
2. Innovation, including:
 - a. Entrepreneurship
 - b. Leadership
3. Social Responsibility, including:
 - a. Ethics
 - b. Diversity
 - c. Critical and engaged citizenry embedded in a local and global context
4. Personal Development, including:
 - a. Self-awareness
 - b. Self-directed and life-long learning
5. Broad understanding of their chosen discipline and/or profession, including:
 - a. An appropriate discipline or professional approach to knowledge production
 - b. Workplace adaptability

Engineering students completing this qualification will be able to demonstrate competence in 10 Graduate Attributes. The Graduate Attributes are stated generically and may be assessed in various engineering disciplinary or cross-disciplinary contexts in a provider-based or simulated practice environment.

- **Graduate Attribute 1: Problem Solving**
Students will be required to apply engineering principles to systematically diagnose and solve *broadly-defined* engineering problems.
- **Graduate Attribute 2: Application of scientific and engineering knowledge**
Students will be required to apply knowledge of mathematics, natural science, and engineering sciences to defined and applied engineering procedures, processes, systems and methodologies to solve *broadly-defined* engineering problems.
- **Graduate Attribute 3: Engineering Design**
Students will be required to perform procedural and non-procedural design of broadly defined components, systems, works, products or processes to meet desired needs normally within applicable standards, codes of practice and legislation.
- **Graduate Attribute 4: Investigation, experiments and data analysis**
Students will conduct investigations of *broadly-defined* problems through locating, searching and selecting relevant data from codes, databases and literature, designing and conducting experiments, analysing and interpreting results to provide valid conclusions.
- **Graduate Attribute 5: Engineering methods, skills, tools, including Information technology**
Students will demonstrate the use of appropriate techniques, resources, and modern engineering tools, including information technology, prediction and modelling, for the solution of *broadly-defined* engineering problems, with an understanding of the limitations, restrictions, premises, assumptions and constraints.
- **Graduate Attribute 6: Professional and Technical Communication**
Students will be required to demonstrate the ability to communicate effectively, both orally and in writing, with engineering audiences and the affected parties.
- **Graduate Attribute 7: Sustainability and Impact of Engineering Activity**
Students will be required to demonstrate knowledge and understanding of the impact of engineering activity on the society, economy, industrial and physical environment, and address issues by analysis and evaluation.

- Graduate Attribute 8: Individual, Team and Multidisciplinary Working**
 Students will be required to demonstrate knowledge and understanding of engineering management principles and apply these to one's own work, as a member and leader in a team and to manage projects.
- Graduate Attribute 9: Independent Learning**
 Students will be required to engage in independent and life-long learning through well-developed learning skills.
- Graduate Attribute 10: Engineering Professionalism**
 Students will be assessed on their comprehension and application of ethical principles and commitment to professional ethics, responsibilities and norms of engineering technology practice.

BE2 MINIMUM ADMISSION REQUIREMENTS

The minimum entry requirement is the National Senior Certificate or the National Certificate (Vocational) with appropriate module combinations and levels of achievement as defined in the *Government Gazette*, Vol. 751, No. 32131 of 11 July 2008, and in the *Government Gazette*, Vol. 533, No. 32743, November 2009. In addition, the minimum admission requirements, rule G7, is stipulated in the General Rules Handbook.

Further to the above, the following are required for admission into BEngTech (Electronic Engineering) programme:

(A) NSC, NCV, SC:

Compulsory Subjects	National Senior Certificate	National Certificate (Vocational)	Senior Certificate	
	Rating	Mark	HG	SG
English	4	60%	E	C
Mathematics	4	70%	E	C
Physical Science	4	70%	E	C
Life Orientation		60%		
		+ 2 Vocational Subjects (70%)		

Note:

- The exit certificate of the candidate must qualify the candidate for degree study (Bachelor's Pass) at an institution of higher learning.
- The NSC subjects Mathematical Literacy and Technical Mathematics will not be accepted as a substitute for the NSC subject Mathematics.

- (3) The NSC subject Technical Science will not be accepted as a substitute for the NSC subject Physical Science.
- (4) Applicants will be ranked according to the sum of their scores for Mathematics and Physical Science, subject to a minimum combined score of 120.

(B) OTHER:

Applicants that qualify for degree study (Bachelor's Pass) at an institution of higher learning but do not meet the departmental mathematics and/or physical science requirements, may present the following N4 subjects, for consideration for entry to the BET programme:

- Mathematics and Engineering Science, plus any two of the following:
- Industrial Electronics OR Electronics
- Digital Systems OR Logic Systems
- Electrotechnics

The above subjects must be passed with a minimum of 50% and all in the same sitting. Students will then be considered alongside the NSC students according to the sum of their marks for N4 Mathematics and Engineering Science, subject to a minimum combined score of 120.

Applicants may present a cognate level 6 Diploma for entry into the BET programme; credit transfer may be considered dependent on the content thereof being presented.

Applicants may present a cognate National N Diploma for entry into the BET programme; credit transfer is not possible.

BE3 PROMOTION TO A HIGHER LEVEL/ PROGRESSION RULES

- (1) All modules have a minimum pass mark of 50%. Moreover, all modules with a summative practical mark will require a minimum pass mark of 50% for the practical component(s).
- (2) A student would not be able to attempt higher-level modules before completing ALL the prerequisite modules.
- (3) In addition to the prerequisite and co-requisite requirements of the individual modules, the student needs to pass all 1st Year modules in order to register for any 3rd Year modules.
- (4) The student must successively register every year and the qualification must be completed within five years of registration.

BE4 UNSATISFACTORY ACADEMIC PROGRESS

- (1) Students who do not meet the progression rules listed above, will be regarded as having Unsatisfactory Academic Progress, and will not be permitted to continue with the degree unless an appeal to continue is upheld, (refer to GI (8) for appeals).
- (2) In modules where a Graduate Attribute (GA) is assessed, the student would need to achieve a final minimum pass mark of 50% as well as be deemed competent in achieving the GA. **A student that achieves a final minimum pass mark of 50% but fails to achieve the GA would fail the module.**
- (3) To progress from one study level to the next, a student would need to accumulate a minimum number of credits as indicated in the table below. Students achieving below the minimum credits would be considered as making unsatisfactory academic progress.

END OF PERIOD	MINIMUM CREDITS	MAXIMUM CREDITS
Year 1 (Semester 2)	74	148
Year 2 (Semester 4)	148	296
Year 3 (Semester 6)	222	428

- (4) Students will NOT be allowed to exceed a maximum of 80 credits per semester.

BE5 PROGRAMME STRUCTURE

The programme is structured according to the modules as referred to in the table below. All modules listed are compulsory to qualify in this programme. The programme is offered on a full-time basis and require attendance to lectures. The method by which they will be examined is indicated in each module study guide. The meaning of Pre- and Co-Requisite is given in the G-rules and is not repeated here.

Name of Module	Subject Code	Study Level	Credits	NQF Level	Pre-Requisite	Co-Requisite
Engineering Mathematics IA	EMTA101	I	12	5	Nil	Nil
Engineering Physics IA	EPHA101	I	12	5	Nil	Nil
Electrical Principles I	ELEP101	I	12	5	Nil	Nil
Analogue Electronics IA	ANLA101	I	12	5	Nil	Nil
Digital Electronics IA	DGEA101	I	12	5	Nil	Nil
Computer and IT	CPUT101	I	8	5	Nil	Nil
Cornerstone 101	CSTN101	I	12	5	Nil	Nil
Engineering Equipment Issue	ENEQ101	I	0	N/A	Nil	Analogue Electronics IA
First Year Student Experience (FYSE & TFL)	N/A	I	0	N/A	Nil	Nil
Engineering Mathematics IB	EMTB101	I	12	5	Engineering Mathematics IA	Nil
Engineering Physics IB	EPHB101	I	12	5	Nil	Nil
Electrical Principles 2	ELEP201	I	12	6	Electrical Principles I	Nil
Analogue Electronics IB	ANLB101	I	12	6	Analogue Electronics IA	Nil
Digital Electronics IB	DGEB101	I	12	6	Digital Electronics IA	Nil
Technical Literacy	TELC101	I	8	5	Nil	Nil
TOTAL CREDITS SEMESTER I&2			148			

Engineering Mathematics 2A	EMTA201	2	12	6	Engineering Mathematics 1B	Nil
Fundamentals of Power Engineering 2A	FUPE201	2	8	6	Electrical Principles I	Nil
Fundamentals of Instrumentation 2A	FIST201	2	12	6	Engineering Mathematics 1B	Nil
Fundamentals of Signals and Systems 2A	FCMC201	2	12	6	Engineering Mathematics 1B	Nil
Fundamentals of Microcontrollers 2A	MCRD201	2	12	6	Digital Electronics 1B	Nil
Electronic Circuit Design 2A	ECDS201	2	12	6	Analogue Electronics 1B Digital Electronics 1B	Fundamentals of Microcontrollers 2A
Computer Programming 2A	CPTP201	2	12	6	Computer and IT Digital Electronics 1B	Nil
Engineering Mathematics 2B	EMTB201	2	12	6	Engineering Mathematics 2A	Nil
Fundamentals of Control Systems 2B	FCNS201	2	12	6	Fundamentals of Instrumentation 2A	Nil
Communication and Network Systems 2B	FNTW201	2	12	6	Fundamentals of Signals and Systems 2A	Nil
Electronic Circuit Design 2B	ECDS301	2	12	6	Electronic Circuit Design 2A	Nil
Embedded Systems 2B	MCRD301	2	12	6	Fundamentals of Microcontrollers 2A	Nil
Data Analytics and Computation 2B	CPTP301	2	8	6	Computer Programming 2A	Nil
TOTAL CREDITS SEMESTER 3&4			148			



Process Instrumentation 3A	PINA301	3	12	7	Fundamentals of Control Systems 2B	Control Systems 3A
Control Systems 3A	CSYA301	3	12	7	Fundamentals of Control Systems 2B	Process Instrumentation 3A
EM Theory and Wireless Communication 3A	RFEA301	3	12	7	Communication and Network Systems 2B	Nil
Digital Signal Processing 3A	DSPA301	3	12	7	Embedded Systems 2B Data Analytics and Computation 2B	Nil
Electronic Design Project 3A	EDPA301	3	12	7	Electronic Circuit Design 2B	Digital Signal Processing 3A
Innovation Management and Entrepreneurship 3A	PJCT101	3	8	7	Nil	Nil
Process Control Systems 3B	PCSB301	3	12	7	Process Instrumentation 3A Control Systems 3A	Nil
RF Engineering 3B	RFEB301	3	12	7	EM Theory and Wireless Communication 3A	Nil
Renewable Energy 3B	RENE301	3	12	7	Nil	Nil
Digital Image Processing 3B	DSPB301	3	8	7	Digital Signal Processing 3A	Nil
Electronic Design Project 3B	EDPB301	3	12	7	Electronic Design Project 3A	Nil
Engineering Ethics and Professional Skills 3B	PRIMI01	3	8	7	Nil	Nil
TOTAL CREDITS SEMESTER 5&6			132			
TOTAL CREDITS (BEngTech)			428			

Department of Electronic Engineering Bachelor of Engineering Technology (BEngTech)

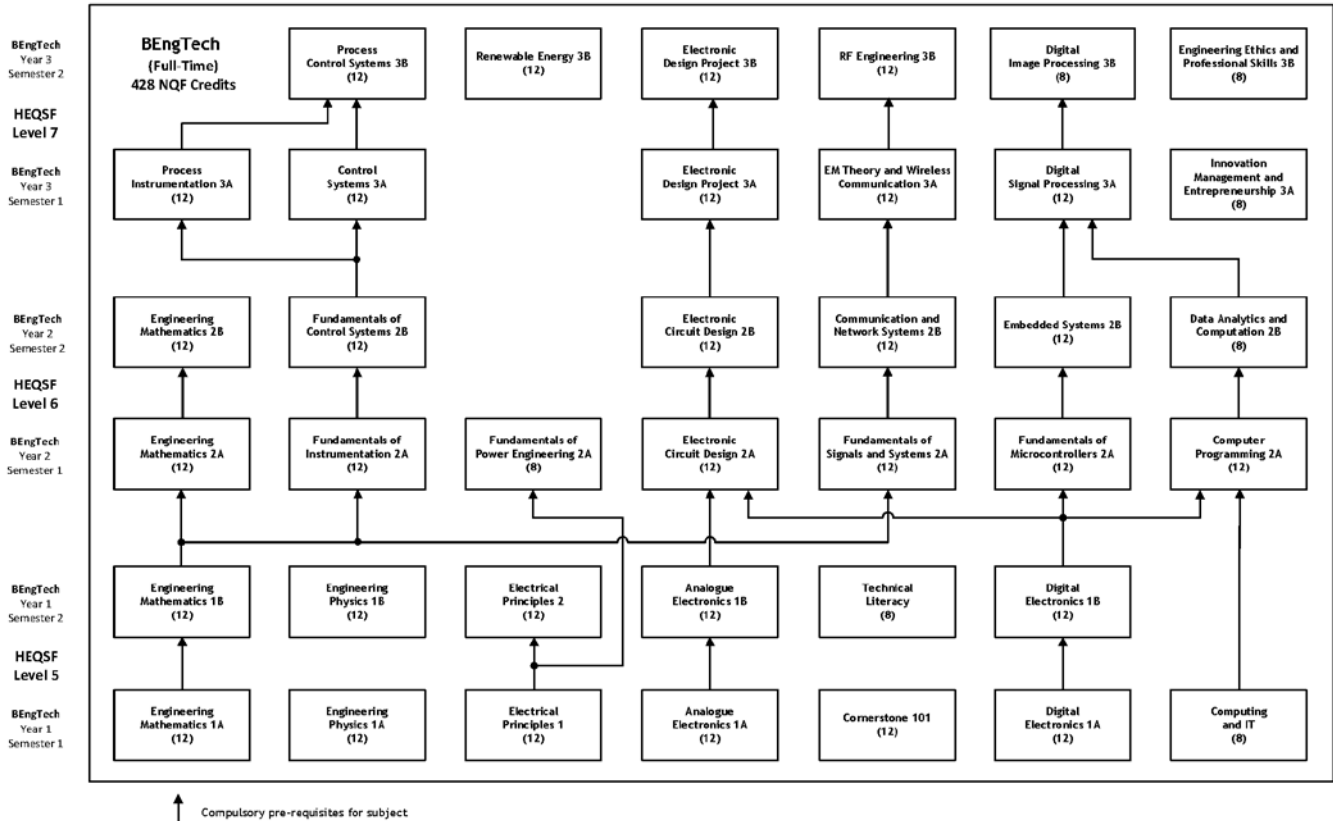

BE6 ABRIDGED MODULE CONTENT

Analogue Electronics IA

This course provides an understanding of the fundamentals of analogue electronics and basic circuit design; teaches construction and analysis of working electronic circuits; and exposes students to appropriate electronic circuits simulation software packages. Topics include semiconductor theory, diode applications, special purpose diodes, transistors, transistors amplifiers, power supplies and test equipment.

Analogue Electronics IB

This module aims to provide the student with analysis and design skills for a wide range of analogue systems; and to expose students to software packages used in simulating various electronic circuits. Topics include output power stages and heatsinks; switching regulators; field effect transistors; differential pair and current sources; operational amplifiers; negative and positive feedback; wave shaping and waveform generators; and filters and their realisations.

Communication and Networks Systems 2B

This course covers the fundamental concepts of data and computer communications, including a basic understanding on computer networks and communication protocols. Topics include time and spectral domain analysis and representation of signals; Fourier domain analysis of linear systems; power spectral density; propagation of signals through linear systems.; filter concepts.; random variables and processes; analogue modulation and demodulation; information theory; sampling theorem; digital modulation schemes; coding theory; digital data communications; topologies; ISO reference model; transmission systems, hubs; switches, CSMA/CD, access points, CSMA/CA, IP, addressing, ICMP, ARP and routers.

Computer Programming 2A

This course covers the fundamental concepts of programming using a high-level computer programming language; and will enable a learner to use a programming language in an application to solve an engineering problem. Introduction to top down design methods; integrated development environments (IDEs); GUI design; structure of a programme: pre-processor directives, declarations, procedures; control structures: relational expressions, control structures, loop structures; programme timers; and file access.

Computing and Information Technology

This course aims to provide a student with the knowledge and understanding of personal computers in terms of hardware, computer operating systems, word processing and spreadsheets; and to expose students to engineering software packages to solve engineering and logical problems. Topics include computer hardware, structure, and operating systems; computer software and the use of applications, explanation of computer networks; security of computer systems, such as computer viruses, malware, phishing etc; applications and demonstration of software to solve

financial, mathematical, and engineering problems and to present results graphically; and portfolio based on computer soft and hardware.

Control Systems 3A

This course uses classical, modern and digital control theories and techniques control to design control systems. Topics include compensator (including PID controller) design using time and frequency domain techniques; control system design using the state space approach and including pole placement design and observer design; introduction to digital control; discretization of continuous-time state space systems; realization theory; stability of digital systems; and digital control system design.

Cornerstone 101

The purpose of this module is to induct students into the community of higher education, with values and practices that promote self-awareness, social justice and environmental sustainability. The module content will be developed around the concept of journeys, across time, across space, and across human relationships. The module will bring different disciplinary perspectives to this content – environmental, historical and sociological. The metaphor of the journey will be sustained across the module and will be applied to personal journeys, historical, political and environmental journeys, and social journeys, with a specific focus on gender. Each section will draw in issues of ethics, diversity and critical citizenry.

Data Analytics and Computation 2B

Data analytics is the science of examining raw data with the purpose of drawing conclusions about that information. It is used in many industries to allow companies and organizations to make better business decisions and in the sciences to verify or disprove existing models or theories. Data analytics is also used in engineering decision making as well as for the understanding of phenomena to assist in better engineering design for socio-technical systems. This module will include the development of mathematical and processing techniques for data analysis. Topics include an overview of data analytics including example applications in areas such as finance, web, marketing etc; introduction to exploratory data analysis, including data summarization, exploratory statistics and visualizations such as boxplots, histograms and scatter plots; common pre-processing techniques such as data cleaning and feature selection; computer software and programming: application of software tool for data analysis, such as Python and MATLAB; Machine Learning: introduction to different categories of machine learning such as supervised and non-supervised learning algorithms; and application of classification, clustering and regression models such as k-means, decision trees, Bayesian classification, linear regression, support vectors machines and ensemble methods.

Digital Electronics 1A

This module aims to provide the fundamental principles of digital systems and covers thoroughly both traditional and modern methods of digital systems; and to promote student understanding of logical principles and applied design applications for direct

entry into industry. Topics include introduction to digital electronics, number systems and coding, basic logic functions, logic tools and techniques, combinational logic circuits, introduction to sequential logic, simulation of logic circuits, introduction to programmable logic devices (PLDs).

Digital Electronics 1B

The purpose of this course is to apply the foundations of the pre-requisite digital electronics module in a broad spectrum of varying digital circuit applications encountered in modern technology. Topics include sequential logic circuits; multivibrators; data converters; memory technology; PLD configuration and programming; IC technologies; and displays

Digital Image Processing 3B

The purpose of this course is to understand the fundamentals of digital image processing and digital image filter design; and to develop the theoretical and practical expertise of students in modelling, manipulating, and extracting information from, digital images and video. Students must be able to present various techniques in modelling and designing digital audio and image filters. Topics include digital audio and image processing fundamentals; intensity transformation and spatial filtering; image filtering in the frequency domain; colour image processing; and image compression.

Digital Signal Processing 3A

The aim of this module is to understand the fundamentals of digital signal processing and digital filter design; and to develop the theoretical and practical expertise of students in modelling and representing digital signals and systems. Students must be able to present various techniques in modelling and designing digital filters and perform spectral analysis. Topics include an overview of systems and signal; signal energy and power; signal symmetry; decimation and interpolation; sampling theorem and aliasing; discrete – time systems; LTI systems; causality ; response of digital filters; difference equations; impulse response; discrete convolution ; the z-transform/inverse z - transform ; region of convergence (ROC); poles, zeros, and the z-plane; transfer functions; discrete time Fourier transform ; frequency response and filter characteristics; FIR and IIR filter design; and multirate digital signal processing.

Electrical Principles I

This subject reinforces the concepts and principles of electrical engineering. It requires the student to apply established electrical concepts, principles and theorems in problem solving for electrical circuits. Topics include established electrical principles and laws; network theorems, conversions and applications; and passive components in DC circuits.

Electrical Principles 2

This course will provide the student with the necessary foundational knowledge for understanding diverse applications in electrical engineering; and teach the fundamentals of electrical circuit analysis. Topics include an introduction to alternating current (AC); capacitor and inductor in AC circuit; RC and RL circuits; RLC circuits and resonance; analysis of AC circuits; network theorems and conversions; and introduction to three-phase systems.

Electronic Circuit Design 2A

This course fully utilizes knowledge learned in all the fundamental electric and electronic modules for advanced circuit modelling, design, and simulation. The module contributes to engineering science through circuit analysis, problem solving, computer simulations, and applications of mathematics, physics, and electronics. Throughout this course, students will gain practical circuit design skills and apply them to real-world electronic product development. Topics include safety issues; electrostatic discharge protection; review of basic instruments (physical and virtual); review of electronic components; function of equipment; features of equipment; characteristics of equipment; electronic test equipment; measurement techniques; standards and calibration; power sources such as basic power supply circuits, batteries, etc.; operational amplifier circuits (inverting and non-inverting amplifiers, summers, etc.); limitations and strengths of integrated circuit operational amplifiers; analogue filter circuits; nonlinear operational amplifier circuits; simple oscillators; interface circuits to motors, relays, lamps, etc., using discrete transistors (bipolar and MOSFET); fundamentals of engineering design; basic sensor concepts - how circuits see, feel, hear, etc.; LED's, lasers, phototransistors, and other interesting optoelectronic devices; useful circuit building blocks and tricks; digital-to-analogue and analogue-to-digital concepts; digital and analogue circuit integration; building analogue and digital prototype circuits; debugging prototype circuits; introduction to CAE for PCB design; introduction to CAE for simulation of circuits; design and construction of integrated digital and analogue circuits; and project documenting and reporting.

Electronic Circuit Design 2B

This course will complement Electronic Circuit Design 2A, with emphasis being made on integrated digital and analogue circuit design. Topics include a review of engineering design processes – conceptual, preliminary, final design and; implementation; analogue-to-digital conversion; sensors; introduction to modular circuit design; integration of analogue, digital and microcontroller systems; designing integrated modular prototype circuits; modular circuit simulation; building integrated modular prototype circuits; debugging integrated modular prototype circuits; design project; project documenting and reporting; and project presentation.

Electronic Design Projects 3A

This module involves the application of knowledge attained during the programme. Students will be placed into groups and collectively apply engineering principles to systematically diagnose and solve broadly-defined engineering problems. Each group will demonstrate their knowledge in applying engineering principles to project development and design, and analysis of results; as well as demonstrate effective communication (both orally and in writing within an engineering context) and time management.

Electronic Design Projects 3B

This module involves the application of knowledge attained during the programme. Each student will apply engineering principles to systematically diagnose and solve broadly-defined engineering problems. Each student will demonstrate his/her knowledge in applying engineering principles to project development and design; and analysis of results; as well as demonstrate effective communication (both orally and in writing within an engineering context) and time management.

EM Theory and Wireless Communication 3A

This module introduces electromagnetic (EM) communications theory and wireless systems. Topics include electromagnetic waves and the electromagnetic spectrum: the need for modulation; RF communication: the RF spectrum; the role of an antenna in a wireless communications system; the decibel scale; power measurement in dBW and dBm; gain and attenuation measurement in dB; free space propagation and path loss; reflection, refraction and diffraction; electromagnetic wave on an open-wire transmission line and the concept of characteristic impedance; antenna fundamentals: radiation mechanism of a half-wave dipole; fundamental parameters of antennas including gain, polarisation, impedance, beam width and; bandwidth; design of a linear wire half wave dipole using software; analogue modulation: AM and FM ; digital modulation; ASK, FSK, PSK, QPSK and QAM; fibre-optic communication: light propagation in fibre; transmitter devices and circuits; receiver devices and circuits; and link analysis.

Embedded Systems 2B

This course will provide a general introduction to embedded system design using RISC technology. Embedded systems contain both hardware and software components and therefore a hardware/software co-design is emphasized. The course will give a basic knowledge on specification methods, design representations (computational models) as well as related design methods. Special emphasis will be put on interface synthesis and low-power design methods. Topics include an overview of embedded systems; background concepts for embedded systems; designing, testing and running embedded systems; CISC vs RISC (concept, architecture, and instruction set); RISC processor programming and debugging techniques (JTAG); embedded C language; timers; serial and parallel communication; ADCs, PWM, interrupts and more.; interfacing LEDs, motors, buzzers, LCDs, sensors, etc.; RTOS; introduction to FPGAs; and VHDL for FPGAs.

Engineering Ethics and Professional Skills 3B

The purpose of this module is to provide students with an overview of engineering ethics and professional skills. Topics include ethics for multicultural societies and workplaces; why be ethical; workplace ethics; professional ethics for engineers and others who work with them; ethics in engineering; skills for handling dilemmas; sustainability concerns and the move toward sustainable development; EIA as the only mandatory tool under environmental legislation; and corporation and sector technology strategies to address current and future sustainability challenges.

Engineering Mathematics IA

This module comprises of the mathematical knowledge and skills which are necessary to underpin the general engineering science that is assumed to be essential for most engineering graduates. The course will provide insight to understand and analyse the engineering problems scientifically based on Mathematics. Topics include **numbers and algebra**: algebra, partial fractions, logarithms, exponents, hyperbolic functions; **areas and volumes**: the circle and its properties, volumes and surface areas of common solids; **trigonometry**: introduction to trigonometry, trigonometric waveforms, cartesian and polar coordinates, trigonometric identities & equations; **graphs**: functions & their curves; **complex numbers**: Euler's and De Moivre's formulas and theorems; **differentiation**: introduction to differentiation, methods of differentiation, applications of differentiation, differentiation of implicit functions, logarithmic differentiation; and **integration**: standard integration, applications of integration.

Engineering Mathematics IB

This module comprises of the mathematical knowledge and skills which are necessary to underpin the general engineering science that is assumed to be essential for most engineering graduates. The course will provide insight to understand and analyse the engineering problems scientifically based on Mathematics. Topics include **linear algebra**: the theory of matrices and determinants, solution of simultaneous equations by matrices and determinants; **trigonometry**: relationship between trigonometry and hyperbolic functions, compound angles; **series**: Maclaurin Series; **differentiation**: differentiation of parametric equations, differentiation of hyperbolic functions, differentiation of inverse trigonometry and inverse hyperbolic functions, partial differentiation, total differentiation, rates of change & small change, maxima, minima and saddle points for function of two variables; **integration**: integration using algebraic substitutions, integration using trigonometry and hyperbolic substitutions, integration by partial fractions, t-substitution, integration by parts, applications of integration; **differential equations**: solution of first-order ordinary differential equations (ODEs), separation of variable, homogenous first-order ODEs, linear first-order ODE; and **statistics and probability**: presentation of statistical data, measures of central tendency.

Engineering Mathematics 2A

This module comprises of the mathematical knowledge and skills which are necessary to underpin the general engineering science that is assumed to be essential for most engineering graduates. The course will provide insight to understand and analyse the engineering problems scientifically based on Mathematics. Topics include **partial differential equations**: introduction to partial differential equations (PDEs); **statistics and probability**: introduction to probability theory, probability, the binomial and Poisson distributions, normal distribution linear regression; **differential equations**: second-order differential equations; **Laplace transforms**: Introduction to Laplace transforms, properties of Laplace transforms, inverse Laplace transforms, solution of differential equations using Laplace transforms, solution of simultaneous differential equations using Laplace transforms; and **Fourier series**: Fourier series for periodic functions of period 2π , Fourier series of non-periodic functions over period 2π .

Engineering Mathematics 2B

This module comprises of the mathematical knowledge and skills which are necessary to underpin the general engineering science that is assumed to be essential for most engineering graduates. The course will provide insight to understand and analyse the engineering problems scientifically based on Mathematics. Topics include **analysis and calculus**: multivariable functions, double and multiple integrals, line and surface integrals, integral theorems, linear optimisation, the simplex method, non-linear optimisation, vector analysis; **linear algebra**: matrix methods, eigenvalue problems, matrix decomposition, systems of ordinary differential equations; **complex analysis**: properties of complex numbers, derivatives of complex numbers, manipulation of complex numbers; **partial differential equations**: Poisson's and Laplace's equations, potential, heat and wave equations; and **z-transforms**: introduction to z-transforms.

Engineering Physics IA

Engineering physics will focus on the general application of mathematical and scientific principles of physics to the analysis and evaluation of engineering problems. Topics in units, physical quantities, vectors; equilibrium of a particle; Newton's second law, gravitation; work and energy; impulse and momentum; torque; elasticity; mechanical waves; vibrating bodies; and acoustic phenomena.

Engineering Physics IB

Engineering physics will focus on the general application of mathematical and scientific principles of physics to the analysis and evaluation of engineering problems. Topics include atomic and molecular structure; Coulomb's law; current, resistance and capacitance; the magnetic field; inductance; Maxwell's equations; electromagnetic waves; the nature and propagation of light; and thermodynamics.

Fundamentals of Control Systems 2B

Introduction to control systems engineering. Topics include open and closed loop systems; system models, for example, differential equations, state space representation, transfer functions, block diagrams and signal flow graphs; control system inputs, including impulse, step, ramp, parabola, sinusoidal and combinations of these; solution to the models based on the control system inputs; analysis of first and second order system response; time domain specifications and analysis including root locus plots; and frequency domain specifications including Bode, Nyquist and Nichols plots.

Fundamentals of Instrumentation 2A

This module provides an introduction to the instrumentation and control fields. Topics include control loop fundamentals; field measurement devices (temperature, pressure, level and flow); control modes; and instrumentation documentation.

Fundamentals of Microcontrollers 2A

This course introduces students to the field of microcontrollers – what they are and how they work; moreover, how they interface with I/O components, and what considerations the programmer has to observe in hardware-based and embedded programming. Topics include an overview of microprocessors and microcontrollers; microprocessor fundamentals and the microcontroller architecture; brief introduction to assembly language (operations and operands); basic data structures in assembly language; introduction to embedded C language; interface between C and assembly; basic I/O and timing (with analogue output); simple interrupts; intermediate timing; analogue-to-digital conversion (ADC); serial interfaces; advanced parallel I/O (configuration, interrupts); advanced timing (PWM, capture, compare); power management; special operations; rationale for PLD usage; PLD evolution; structure and operation of CPLDs; hardware description language (HDL); implementing PLD-based applications using hardware; state machine design; and PLD testing techniques.

Fundamentals of Power Engineering 2A

This subject introduces the subject of power electronics, which includes the switching, control and conversion of electrical power using semi-conductor devices. Topics include power semiconductor diodes and circuits; diode rectifiers; DC-DC converters; PWM inverters; resonant pulse inverters; thyristors; controlling power using rectifiers; and AC voltage controllers.

Fundamentals of Signals and Systems 2A

This course provides an introduction to the basic concepts and theory of analogue and digital signal processing. Signal processing plays an extremely important role in a wide variety of engineering systems such as communication devices, robotics, automation, aircraft, spacecraft and biomedical systems. Topics include fundamental concepts of signals and systems; time domain models of systems; Fourier series and Fourier transforms; convolution and correlation of signals; Laplace transform and the z - transform; analysis of continuous – time systems by transfer functions; filter concepts and design; and basic concepts of probability, random variables and random signals.

Innovation Management and Entrepreneurship 3A

The purpose of this module is to provide students with an overview of the concepts of innovation management and entrepreneurship. Topics include an introduction and the role of innovation; defining technology management; how technologies and industries evolve; product life cycle; marketing new product; the innovation organisation; entrepreneurship; new business opportunity; and forms of business ownership and modalities of start-ups.

Process Control Systems 3B

This module introduces the students to automation systems, final control elements, loop control techniques, performance indices, plant design engineering, and machine control.

Process Instrumentation 3A

This module introduces the students to process analysers, unit operations, telemetry, control philosophies, process plant engineering, plant documentation and loop control techniques.

Renewable Energy 3B

This subject introduces the subject of renewable energy; this being the study of renewable energy resources, the AC and DC technologies involved as well as the applications in a modern energy conscious society. Topics include energy resources and technologies; energy transfer; sustainable design; power conversion and integration technologies; wind turbines; solar power; marine energy; energy generation from biomass; geothermal energy; waste and energy; DC energy generation and systems; system integration and automation; exploitation of renewable energy resources; and socio-economics of renewable energy.

Radio Frequency Engineering 3B

This module introduces the design of radio frequency circuitry in the VHF and UHF bands, with emphasis on linear circuit design. Topics include an introduction to radio frequency engineering; linear versus non-linear networks; transmission lines; lumped element components at radio frequencies; impedance matching; network characterisation; small-signal amplifier design; noise in two-port networks; low-noise amplifier design; and system level design.

Technical Literacy

This module prepares students to work independently and with groups, to responsibly, appropriately and effectively use technology tools to access, manage, integrate, evaluate, create and communicate technical information. Topics include the differences between language usage in academic, technical and common environments; experimental methods and the scientific method; planning and documenting experiments; technical report writing; plagiarism; referencing practice (DUT-Harvard, IEEE, etc); utilising spreadsheets for graphical presentation of information; and standards (ISO, SABS, etc).

BE7 SUPPLEMENTARY PROGRAMMES

The following two programmes, developed and facilitated by the Centre for Excellence in Learning and Teaching (CELT), have been conceptualised as a means of fostering student success through an integrated holistic approach to higher learning.

First Year Student Experience (FYSE)

This programme is facilitated by senior students called Tutor-Mentor-Advisors (TMAs). The TMAs conduct seminars designed to help first year students in all faculties of DUT understand the way learning, teaching and assessing are done at the university. The seminars build a student-centred educational experience to prepare first-year students to be critical thinkers for an increasingly diverse and complex local, national and globalized work environment. This programme was initiated to specifically address the transition from basic education to Tertiary education, Adaptation into the institutions of higher learning and success of first-year students.

Technology for Learning (TFL)

This is an integrated component of the FYSE. Following the paradigm shift adopted by many institutions of higher learning for technology based educational experience, the Centre for Excellence in Learning and Teaching designed a programme to train students on the online systems of learning readily available in the institution. This initiative seeks to ensure effective use of all the technology tools that would enhance and enable convenient learning experience.

Both programmes, which are **compulsory** for all first-time entering Electronic and Computer engineering students, run concurrently and have a dedicated timeslot in the timetable.

MASTER OF ENGINEERING (MEng)

ME1 GENERAL INFORMATION

This qualification is intended for persons who will contribute, through research, to understanding the application and evaluation of existing knowledge in a specialized area of technology. They will also demonstrate a high level of overall knowledge in that area, ranging from fundamental concepts to advanced theoretical or applied knowledge.

Students who have successfully completed the MEng degree should:

1. Be capable of assimilating and evaluating appropriate literature and resources to the field of study;
2. Be capable of determining and stating the objectives of a specific research topic and planning an appropriate strategy to reach the objectives;
3. Efficiently expedite the research strategy to generate an effective solution;
4. Be capable of evaluating the quality of the solution in terms of the stated objectives.

ME2 MINIMUM ADMISSION REQUIREMENTS

- B-Tech (from an ECSA accredited South African UoT). Additional entrance requirements and/or pre-requisites may apply.
- Bachelor of Engineering Technology Honours (BEngTechHons) degree or an appropriate or related NQF Level 8 Engineering qualification.

NB. There are a limited number of postgraduate spaces available and preference will be given to applicants that have good academic track records and running averages and/or capstone projects above 60%.

Interested students must submit the required supporting documentation; refer to: http://www.dut.ac.za/course/master_of_technology_engineering_electrical_lc/

ME3 AWARD OF THE DEGREE

This degree is awarded to a person who has executed and documented an engineering research project and communicated results by means of a dissertation that is concurred in terms of its content and level by a panel of external examiners and the higher degrees committee of the university. To vindicate the quality of the work undertaken, it is also recommended that the student publish their findings in at least one peer reviewed accredited (ISI/DHET approved) conference or journal prior to submission for examination.

DOCTOR OF ENGINEERING (DEng)

DE1 GENERAL INFORMATION

This doctoral level programme is intended for persons who will make a significant and original contribution to knowledge in a specialised area of technology. They will have a high level of overall knowledge in that specialised area ranging from fundamental concepts to advanced theoretical or applied knowledge.

This qualification combines academic research and scholarship with engineering practice and application. The academic degree awarded, which is based on advanced study, research and thesis in engineering, is an equivalent NQF level 10 qualification as the PhD degree in engineering/applied sciences.

Students who have successfully completed the DEng degree should:

1. Be capable of assimilating and evaluating appropriate literature and resources to the field of study;
2. Be capable of determining and stating the objectives, a specific research topic and planning an appropriate strategy to reach the objectives;
3. Efficiently expedite the research strategy to generate an effective solution;
4. Be capable of evaluating the quality of the solution in terms of the stated objectives;
5. Be capable of guiding inexperienced researchers with research projects;
6. Be capable of synthesizing unique solutions to research problems.

DE2 MINIMUM ADMISSION REQUIREMENTS

- Master of Engineering (MEng) degree or an appropriate or related NQF Level 9 Engineering qualification.

Interested students must submit the required supporting documentation; refer to:
http://www.dut.ac.za/course/doctor_of_technology_engineering_electrical_lc/

DE3 AWARD OF THE DEGREE

This degree is awarded to a person who has initiated and successfully executed research in the field of engineering. The research must be acknowledged as a significant contribution through a thesis that is concurred in terms of its content and level by a panel of external examiners and the higher degrees committee of the university. It is also recommended that prior to submission for examination the student publish their findings in at least one peer reviewed accredited (ISI/DHET approved) journal. These academic recognitions set a seal of approval on the quality of the work undertaken.

RESEARCH

REI GENERAL INFORMATION

The department research committee (DRC), which monitors, promotes and manages all research activities within the department, advises the Head of Department with regards to postgraduate student related issues. Persons interested in pursuing Masters (MEng) or Doctoral (DEng) research in the department should contact the Head of Department, through the secretary and/or prospective supervisor via **email**, together with the following documentation:

- (1) Certified copy of ID document/card (or passport)
- (2) Complete transcripts of undergraduate and/or postgraduate qualification/s. Preference will be given to applicants that have good academic track records with running averages and/or capstone projects above 60%.
- (3) Certified copy of your degree/s (or equivalent qualification/s)
- (4) SAQA certification/s (if applicable)
- (5) Copy of final year capstone project report or Masters dissertation (for DEng applicants) in PDF format.
- (6) Mini proposal (1-2 pages) highlighting intended topic and research
- (7) A list of published journal/conference articles, if any.

If the student meets the admission requirements (based on the above documentation), then s/he will be contacted by the department through a prospective supervisor. For Masters applications, the student will also have to submit a **preliminary research proposal** (contact department for the template) together with the "Notification of Proposed Research Topic and Supervisor" form, which will be tabled for consideration at the DRC.

Note: Both the research proposal and the dissertation/thesis must be **orally** defended by the student in the form of a presentation to members of the DRC and invited faculty members prior to being submitted to FRC and for examination, respectively.

RE2 RESEARCH FIELDS

Academic	Research Field	Description
Mr S Macpherson	RF and Microwave Transmitter and Receiver Systems	Far-field antenna; radio astronomy.
Prof B Nleya	Optical Networks and Network Security	Energy efficient networking, resources allocation and management in all optical networks as well as security and access control in IoT Enabled Networks.
Dr N Pillay	Applied Computational Intelligence	Application of artificial intelligence in the process control, control loop optimization, nonlinear control and controller performance analysis for industrial control systems.
Dr S Reddy	Intelligent Systems	Merging of embedded systems with machine intelligence; includes topics such as machine learning, pattern recognition, image processing and robotic vision, 2D-to-3D conversion, NLP and autonomous systems.
Mr R Sewsunker	Renewable Energy and Energy Efficiency using Distributed Intelligence	Specific focus on the emerging DC paradigm with current work on optimal control methods applied to DC nanogrids and microgrids. Other DC related topics include optimised water pumping, intelligent lighting and smart metering.
Dr O Sokoya	Advanced Physical Layer Technologies	Massive MIMO, OFDM, millimetre wavelength technologies and power line communication.

NATIONAL DIPLOMA: ENGINEERING: ELECTRICAL (LIGHT CURRENT)

NOTE: The current National Diploma: Engineering: Electrical (Light Current) began phasing out in 2017 to allow for the new Bachelor of Engineering Technology in Electronic Engineering. The last cohort of first-time entering students admitted to this National Diploma qualifications was in January 2017.

EL1 GENERAL INFORMATION

The National Diploma: Engineering: Electrical (Light Current) qualification provides a vocationally oriented education that will prepare students to be functional in the field of instrumentation and control engineering or communication engineering to make a meaningful contribution to Industry. The engineering profession contributes to the technical, social, economic and environmental infrastructure of the country, leading to socio-economic growth. A framework of engineering qualifications develops the human resources essential for sustaining the profession.

Within that framework, this qualification is designed for the development of engineering technicians. A graduate with this qualification will be: -

1. Competent to apply an integration of theory, principles, proven techniques, practical experience and appropriate skills, to the solution of well-defined problems in the field of electrical engineering while operating within the relevant standards and codes.
2. Able to work independently, and as a member of a team.

The qualified person will be able to register with the Engineering Council of South Africa (ECSA) as a Candidate Engineering Technician in the field of Electrical Engineering.

EL2 CAREER CHOICES

To be successful in a career in the electronic and computer engineering industry you must have the following traits:

1. Be able to think logically and creatively;
2. Be willing to work hard and have a positive attitude;
3. Have a passion for all technology and specifically electronics;
4. Be prepared for life-long learning;
5. Have excellent technical communication skills;
6. Be prepared to master new technology daily.

The department offers two fields of study streams within the National Diploma: Engineering: Electrical (Light Current) programme: These are:

- (1) Instrumentation and Control (NDEINI)
- (2) Electronic Communications (NDECM1)

(1) Field of Study: Instrumentation and Control (NDEINI)

As an electronic engineering professional, you should be able to justify, design, construct, commission and maintain instrumentation and control systems in a wide range of industries including paper, sugar, vehicle manufacturing, refining, water reticulation and chemical.

Qualified electronic engineering professionals specializing in instrumentation are highly sought after by industry.

The Diploma course includes basic electronics, digital systems, electrical engineering, mathematics, software design and networking. This enables the student to specialise in instrumentation. Some examples of the course material include:

Measurements of variables including pressure, flow, level, temperature, position and mass;

Unit operations (e.g. boilers, distillation columns, refrigeration);

Control systems;

Software design (e.g. PLCs, high level programming);

Final control elements (e.g. drives and valves).

The necessary control theory to effectively utilise systems is also included. All modules are supported by relevant practical work.

(2) Field of Study: Electronic Communications (NDECM1)

As an electronic engineering professional, you will be able to justify, design, construct, commission and maintain electronic and communication systems in a wide range of industry including the telecommunications, mobile wireless, cellular and general electronic manufacturing industries.

Qualified electronic engineering professionals specialising in communications are highly sought after by industry.

The Diploma programme includes core modules such as electronics, digital systems, electrical engineering, mathematics, software design and network systems, with specialist modules such as electronic communications, radio engineering and microwave communications.

All modules are supported by relevant laboratory work which include:

- To fabricate and test electronic circuits
- Manufacturing, testing and maintenance of electronic devices and systems.
- To understand the construction, identification, characteristics, specifications, merits, limitations and applications of electronic components and materials
- To understand lines communication, audio and video communication, and microwave communication

EL3 PROGRAMME STRUCTURE

Notwithstanding all the current rules (both General rules and Departmental Rules) that regulate these diplomas, the last semester in which any student may register for each of the modules is listed as follows:

Module Name	Last Possible semester of Registration
Communication Skills I	July 2017 (Phased out)
Computer Skills I	July 2017 (Phased out)
Electrical Engineering I	July 2017 (Phased out)
Electronics I	July 2017 (Phased out)
Mathematics I	July 2017 (Phased out)
Digital Systems I	July 2017 (Phased out)
Projects I	July 2018 (Phased out)
Electrical Engineering II	July 2018 (Phased out)
Electronics II	July 2018 (Phased out)
Mathematics II	July 2018 (Phased out)
Digital Systems II	July 2018 (Phased out)
Projects II	July 2019
Electronic Communications II	July 2019
Electronics III	July 2019
Mathematics III	July 2019
Digital Systems III	July 2019
Process Instrumentation I	July 2019
Process Instrumentation II	July 2019
Control Systems II	July 2019
Design Project III	July 2020
Microwave Communication III	July 2020
Radio Engineering III	July 2020
Software Design II	July 2010
Network Systems II	July 2020
Process Instrumentation III	July 2020
Control Systems III	July 2020
Experiential Learning I (P1)	January 2021
Experiential Learning II (P2)	July 2021

NOTE: The abridged module content is provided on p. 47.

FIELD OF STUDY I: PROCESS INSTRUMENTATION AND CONTROL (NDEINI)

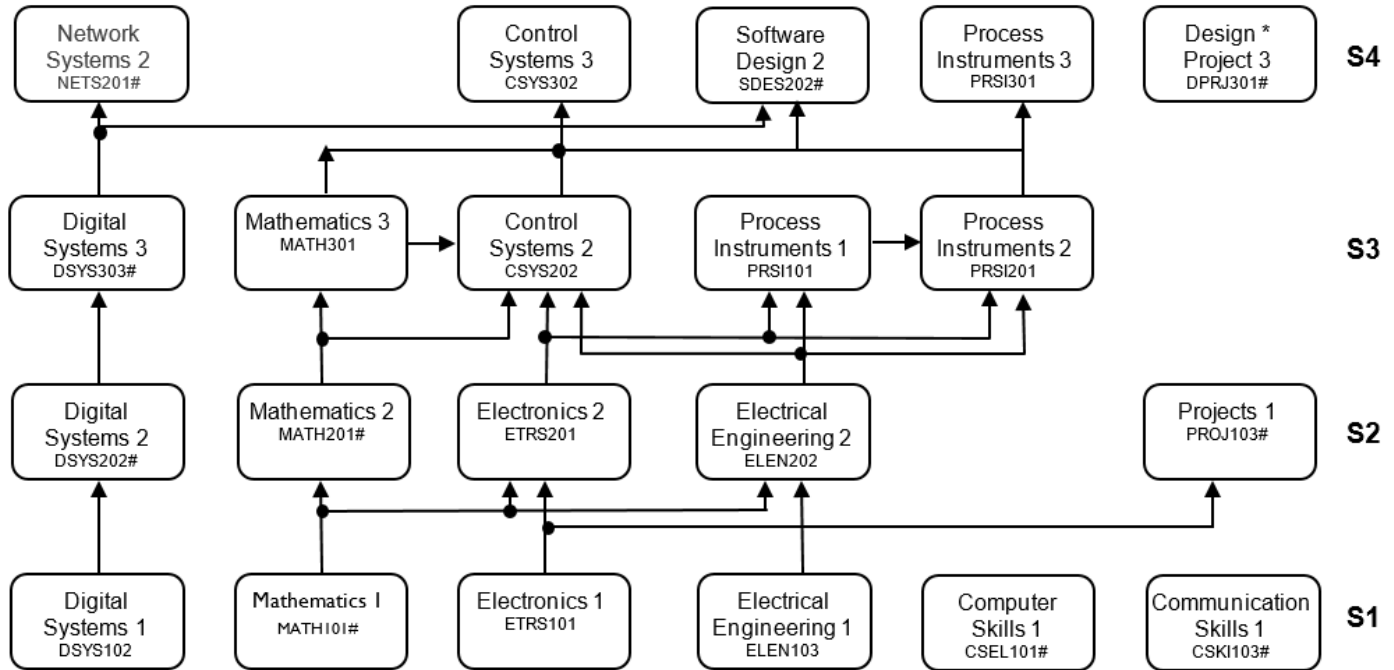

NOTES:

- ↑ Denotes prerequisites, that is, lower level subject must be completed first.
- Denotes complementary, that is, must register for prior to or simultaneously with.
- # Denotes continuous assessment.
- * All S4 level subjects are complementary to Design Project 3.

FIELD OF STUDY 2: ELECTRONIC COMMUNICATIONS (NDECM1)

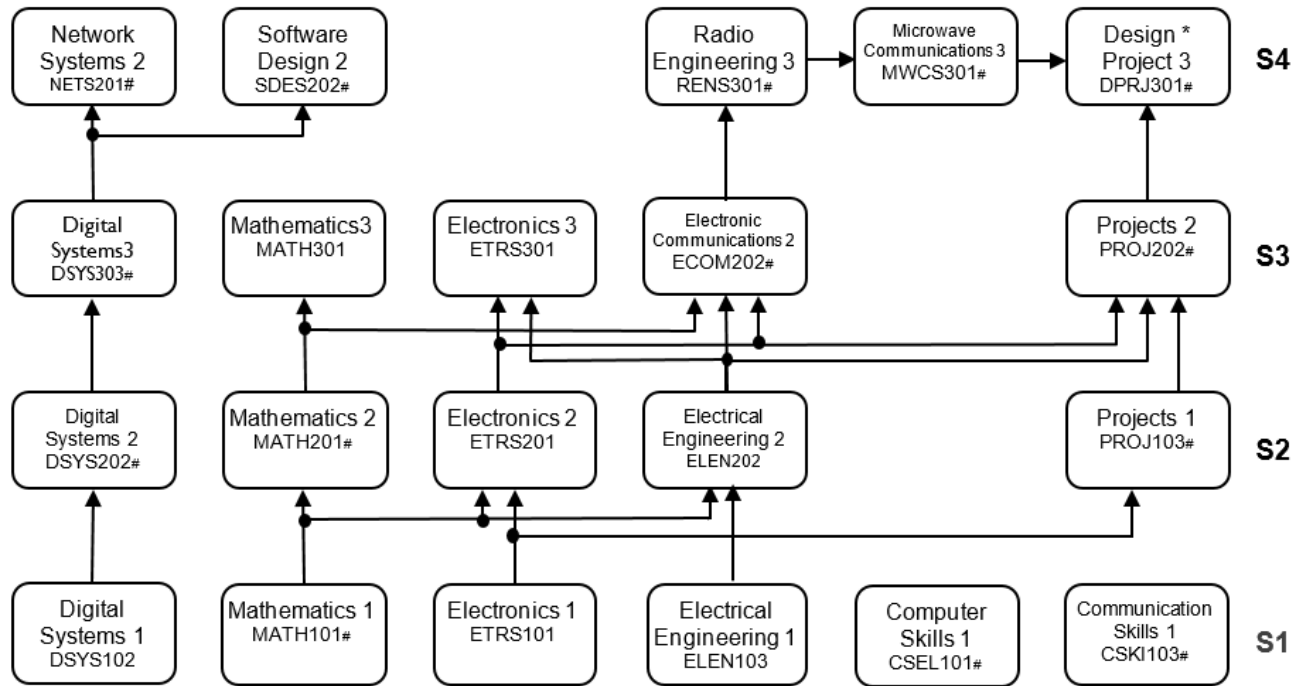

NOTES:

- ↑ Denotes prerequisites, that is, lower level subject must be completed first.
- Denotes complementary, that is, must register for prior to or simultaneously with.
- # Denotes continuous assessment.
- * Radio Engineering 3 and Microwave Communication 3 are complementary to Design Project 3.

NATIONAL DIPLOMA: ENGINEERING: COMPUTER SYSTEMS

NOTE: The current National Diploma: Engineering: Computer Systems began phasing out in 2017 to allow for the new Bachelor of Engineering Technology in Electronic Engineering. The last cohort of first-time entering students admitted to this National Diploma qualifications was in January 2017.

CSI GENERAL INFORMATION

The National Diploma: Engineering: Computer Systems qualification affords a vocationally oriented education that will prepare students to be functional in the field of computer engineering related technologies to make a meaningful contribution to industry. This specialisation provides a foundation in both hardware and software; and prepares students for a career demanding specialist knowledge in computer programming, computer systems, embedded systems and systems analysis. The engineering profession contributes to the technical, social, economic and environmental infrastructure of the country, leading to socio-economic growth. A framework of engineering qualifications develops the human resources essential for sustaining the profession.

Within that framework, this qualification is designed for the development of computer engineering technicians. A graduate with this qualification will be: -

1. Competent to apply the theoretical and practical knowledge and skills of the following: hardware, software, networking and basic engineering aspects in the environment of the computer industry.
2. Competent to apply the integration of theory, principles, proven techniques, practical experience and appropriate skills, to the solution of well-defined problems in the field of computer engineering.
3. Competent in providing professional, technical and developmental support in the computer industry.
4. Able to work independently, and as a member of a team.

The qualified person will be able to register with the Engineering Council of South Africa (ECSA) as a Technician-in-Training in the field of Computer Systems.

CS2 CAREER CHOICES

To be successful in a career in the computer systems industry you must have the following traits:

1. Be able to think logically and creatively;
2. Be willing to work hard and have a positive attitude;
3. Have a passion for all technology and specifically electronics and computer technology

4. Be prepared for life-long learning;
5. Have excellent technical communication skills;
6. Be prepared to master new technology daily.

This qualification is a hybrid electronic engineering and computer engineering course. It is envisaged that the students obtaining this Diploma will be exposed to the following areas of learning:

- Fundamental electronics and electrical Engineering;
- Data communication and networking;
- Computer systems architecture;
- Embedded systems (microcontrollers);
- Computer programming;
- Database systems; and
- Operating systems.

Graduates of the National Diploma: Engineering: Computer Systems programme find work opportunities in a wide spectrum of industries. The following are some of the major destinations: Telecommunication and data networking companies, embedded systems designers, IT infrastructure (design, installation and support), Industry Programmers.

CS3 PROGRAMME STRUCTURE

Notwithstanding all the current rules (both General rules and Departmental Rules) that regulate these diplomas, the last semester in which any student may register for each of the modules is listed as follows:

Module Name	Last Possible Semester of Registration
Communication Skills I	July 2017 (Phased out)
Computer Skills I	July 2017 (Phased out)
Programming I	July 2017 (Phased out)
Electrical Engineering I	July 2017 (Phased out)
Electronics I	July 2017 (Phased out)
Mathematics I	July 2017 (Phased out)
Digital Systems I	July 2017 (Phased out)
Projects I	July 2018 (Phased out)
Programming II	July 2018 (Phased out)
Digital Communications II	July 2018 (Phased out)
Electronics II	July 2018 (Phased out)
Mathematics II	July 2018 (Phased out)
Digital Systems II	July 2018 (Phased out)
Operating Systems III	July 2019
Programming III	July 2019
Network Systems II	July 2019
Systems Analysis II	July 2019
Mathematics III	July 2019
Digital Systems III	July 2019
Design Project III	July 2020
Software Engineering III	July 2020
Network Systems III	July 2020
Database Principles III	July 2020
Logic Design III	July 2020
Microprocessors III	July 2020
Experiential Learning I (P1)	January 2021
Experiential Learning II (P2)	July 2021

NOTE: The abridged module content is provided on p. 45.

COMPUTER SYSTEMS (NDCSY2)

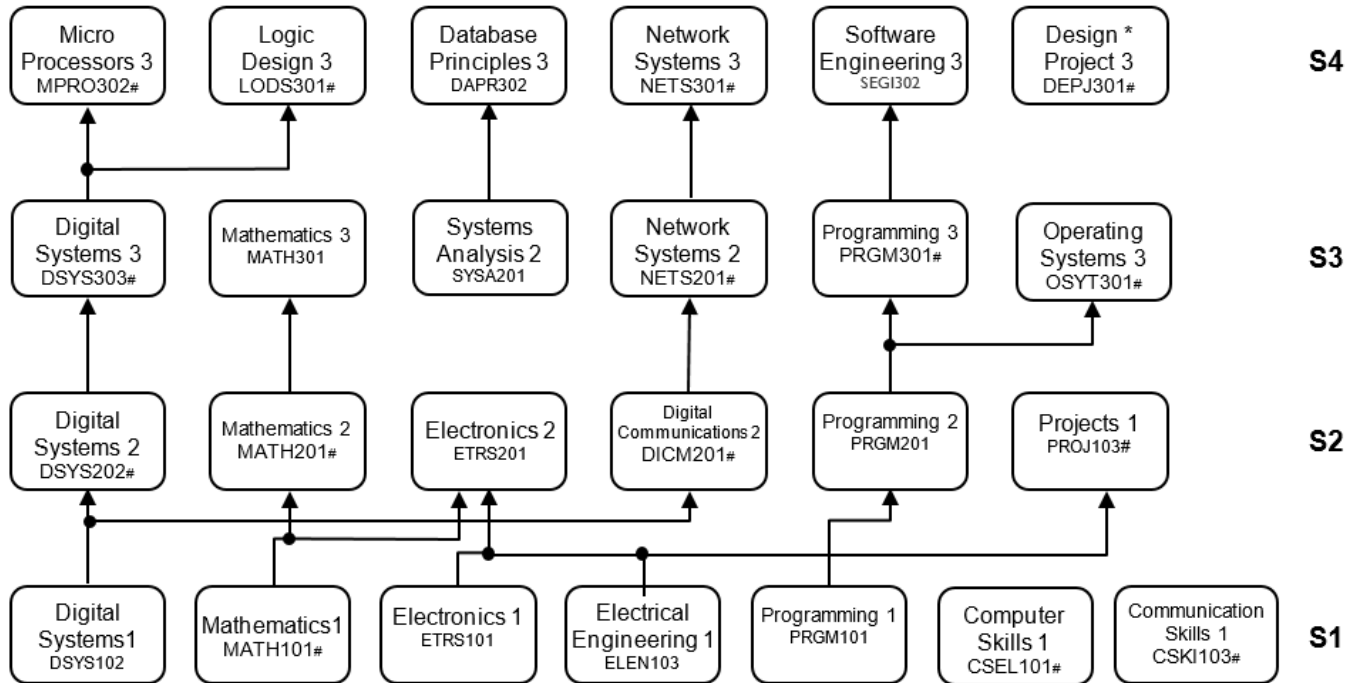

NOTES:

- ↑ Denotes prerequisites, that is, lower level subject must be completed first.
- Denotes complementary, that is, must register for prior to or simultaneously with.
- # Denotes continuous assessment.
- * All S4 level subjects are complementary to Design Project 3.

NATIONAL DIPLOMA: ENGINEERING ELECTRICAL (LIGHT CURRENT) & COMPUTER SYSTEMS

LCI MINIMUM ADMISSION REQUIREMENTS

In addition to the general admission requirements as stated in the General Rules, the following minimum requirements (or their equivalent) shall apply:

(1) Senior Certificate Requirements:

Mathematics: E (HG) C (SG)

Physical Science (or equivalent): E (HG) C (SG)

In addition, a student must obtain a minimum score of 35 using the scoring system listed in Table I to be conditionally accepted into the programme. The scores for each Senior Certificate module result obtained are added together, with the Mathematics and Physical Science scores multiplied by a factor of 2.

Symbol	A	B	C	D	E	F
SC (Higher Grade)		7	6	5	4	3
SC (Standard Grade)		5	4	3	2	1
NSC		6	5	4	3	2

(2) National Senior Certificate Requirements:

Mathematics: 4 (Adequate achievement)

Physical Science: 4 (Adequate achievement)

English (Primary): 4 (Adequate achievement)

OR

English (First additional): 4 (Adequate achievement)

Note

(1) The module Mathematical literacy will not be accepted as a substitute for the module Mathematics.

(2) Paper Three in Mathematics (Geometry) is a co-requisite for Engineering Mathematics I and is compulsory for all applicants unless the applicant has passed Paper Three with a minimum rating of 4 (Adequate achievement).

In addition, a student must obtain a minimum score of 28 using the scoring system listed in Table I to be conditionally accepted into the programme. The scores for each National Senior Certificate module result obtained are added together, with the Mathematics and Physical Science scores multiplied by a factor of 2.

(3) **National Technical Certificate N4:**

A student having an N4 Certificate with passes of 50% or higher in four (4) relevant modules including Mathematics and Electrotechnics, or an equivalent SAQA NQF Level 4 qualification, as well as compliance with the English language requirements as stated in the General Rules, will be accepted provided there is available space. NB. S1 credits may be given for equivalent modules passed, with a minimum of 50%, at both the N5 **and** N6 level, on a case-by-case basis.

(4) **National Certificate Vocational Level 4**

National Certificate Vocational with a minimum mark of 60% in English, Mathematics, Physical Science or equivalent, Life Orientation *and* 2 vocational modules relevant to the field of electrical engineering.

Note: The last cohort for first time registration for the National Diploma in the department was January 2017.

LC2 SELECTION

Owing to the limited number of places available, admission into the programme will be done taking the following factors into consideration:

- (1) Academic performance at National Senior Certificate (or Senior Certificate), N4 certificate, National Certificate Vocational (NCV), or equivalent SAQA NQF level 4.

LC3 DURATION OF STUDIES

The minimum duration of academic studies at the Durban University of Technology shall be four semesters (2 years), unless credits for studies at another institution have been granted.

LC4 AWARD OF DIPLOMA

- (1) The diploma will only be awarded where a student has successfully completed the requisite number of modules, as listed in the relevant field of study, and in addition has completed a minimum of two semesters of appropriate work integrated (experiential) learning. The diploma will be awarded after a minimum period of three years.
- (2) All modules, as listed under the relevant field of study, are to be completed at DUT unless prior written permission is granted by the HOD for the student to register at an alternative institution.
- (3) Diplomas are not automatically awarded to candidates who have satisfied all the requirements for each instructional programme. The onus is on the student to apply to the University for the Award of the Diploma. In this regard the candidate should obtain the necessary forms from the Secretary of the Department.

LC5 REGISTRATION

- (1) All students registering for the programme for the first time will be required to pay a toolkit levy in addition to the standard course fee.

- (2) No registration for any module will be allowed later than one week after commencement of lectures without prior written permission from the Head of Department. Furthermore, any late registration is conditional, module to the student having attended all lectures and practical sessions during the late registration week.
- (3) No student will be allowed to register for a higher-level module if there is a timetable clash with any other module.

LC6 STUDENT CONDUCT

- (1) Eating, smoking or drinking in any lecture venue or laboratory is forbidden.
- (2) Safety rules must always be strictly observed.
- (3) Students are required to have a toolkit for laboratory sessions.
- (4) All equipment issued to a student during a laboratory session must be returned at the end of the laboratory session.
- (5) Mobile phones are to be switched off during lecture, laboratory and assessment sessions.

LC7 PROMOTION TO A HIGHER LEVEL

- (1) A student may not register for higher level academic modules unless all prerequisites are complied with.
- (2) A student may not register for any semester 3 academic modules without having obtained credits for all semester 1 academic modules.
- (3) A student may not register for any semester 4 academic modules without having obtained credits for all semester 2 academic modules.

LC8 UNSATISFACTORY ACADEMIC PROGRESS

- (1) A student who does not obtain a credit for a module after having twice been registered for that module will not be allowed to re-register for that module. A student wishing to appeal against this rule may apply to the Department. Re-registration may be granted at the discretion of the Appeals Committee.
- (2) A student must pass ALL the specified modules for the diploma within a **maximum** of eight registered semesters of study. A student wishing to appeal against this rule may apply to the Department. Re-registration may be granted at the discretion of the Appeals Committee.

LC9 SEMESTER MARK

- (1) The semester mark for all examinable modules is set at 40% of the final mark.
- (2) A student who for any reason is absent from a test, assessment, or scheduled laboratory period, must provide acceptable proof of their reason for absence to the lecturer concerned within two days after returning to classes. Failure to provide proof of acceptable reasons for absence, or failure to undergo a specified alternative assessment, shall result in a zero mark for that test/assessment.

LC10 METHOD OF ASSESSMENT

Modules are evaluated through class tests and/or an examination and a practical/assignment mark. Those modules marked with # are evaluated through a process of continuous assessment. Further details of the method of assessment are included in the module study guide.

LC11 SUB-MINIMUM

- (1) A sub-minimum of 50% will apply to the practical component of all semester marks.
- (2) A sub-minimum of 40% will apply to all semester marks.
- (3) A sub-minimum of 40% will apply to all written examinations.

LC12 SUPPLEMENTARY EXAMINATIONS

- (1) Supplementary examinations are offered for all examinable modules. Students who have failed an examinable module qualify for the supplementary examination if they have obtained a final mark (semester mark and examination mark) of at least 45%. A semester mark is only valid for one examination and one supplementary session.
- (2) A final examination is not written in modules evaluated through continuous assessment and if the required pass mark is not attained the module must be repeated.

LC13 WORK INTEGRATED LEARNING

- (1) Students may register for work integrated learning at any point in the programme after completing semester I.
- (2) A student must register for work integrated learning with the department immediately on starting a period of learning in industry. Registration forms are available in the departmental offices. Unregistered periods of work integrated learning will not be considered for credit purposes.
- (3) If any of the registered details regarding work integrated learning change (e.g. employer, supervisor, address, telephone numbers etc.), the student must advise the department in writing within two weeks of the changes.
- (4) A student may not register for the second period of work integrated learning without having submitted the manual (online or otherwise) for the first period of work integrated learning.
- (5) Registration for the second period of work integrated learning will be treated as provisional until the department has approved the student's completion of the requirements for the first period of work integrated learning.
- (6) A student may not register for more than one academic module with the department while registered for work integrated learning.

LC14 SERVICE DEPARTMENTS

Students are referred to the departmental handbooks and module study guides for information regarding the rules applicable to modules serviced by other departments.

LC15 CONTACT TIME

For each module, except for Communication Skills 1, Computer Skills 1, Design Project 3 and Industrial Project 4, contact time per week is made up of four lecture periods and two periods devoted to either practical work or tutorials.

Computer Skills 1 and Communication Skills 1 each have one lecture period and two practical/tutorial periods per week.

Design Project 3 has two formal lecture periods per week. In addition, the student is expected to devote eight hours per week to unsupervised work on a design project.

Industrial Project 4 requires the student to devote 300 hours to the completion of an industry-based project. Most of this time will be unsupervised work on the project with regular report back meetings with a member of the academic staff in the department.

LC16 SELF-STUDY

A student should set aside four hours per day (weekends included) for self-study and revision of work covered in lectures. In addition to this time will be required to prepare for tests, exams and to complete assignments.

LC17 FIELDS OF STUDY

The department offers three fields of study in the National Diploma (ND) in Electrical Engineering (Light Current); these are:

- (1) ND: Engineering: Electrical (LC): Instrumentation and Control (NDEIN1)
- (2) ND: Engineering: Electrical (LC): Electronic Communications (NDECM1)
- (3) ND: Engineering: Electrical (LC): Computer Systems (NDCSY2)

LC18 ABRIDGED MODULE CONTENT

Communications Skills I

Communication theory, oral presentation, technical writing, group communication skills.

Computer Skills I

Computer Hardware including CPU, RAM, ROM, ALU and peripheral devices; Overview of Networks covering LAN, WAN, Internet, Intranet; File Management in the Windows environment; Performing mathematical calculations including conditional branching in Excel Spreadsheet; Word processing using MS Word covering tables, templates, Headers, Footers, Paragraphs, editing, savings, printing. Formatting.

Control Systems 2

Introduction to control systems and MATLAB. Dynamic models of physical systems. Standard control systems inputs. Solutions to transfer function and state space models. Transient and steady state response of first and second order systems. Time domain specifications of systems. Routh-Hurwitz stability criterion.

Control Systems 3

Control system design tools. Root locus plots. Frequency domain specifications, Bode plots, polar plots, log-magnitude versus phase plots and Nichols chart plots. Relation between frequency and time domain for second order systems. Introduction to compensator design. Simple designs.

Database Principles 3

Introduction to file systems and database systems. Data models. The relational database model. Entity relationship (ER) modelling. Normalisation of database tables. Advanced data modelling. Introduction to Structured Query language (SQL). Database design. Database connectivity. (project)

Design Project 3

The design, construction, testing and documentation of a complete project.

Digital Communication 2

Data communications and networking basics: overview; applications and networking terminology; digital communications basics; protocol basics; protocol stacks. Telephone networks and modems: introduction; transmission systems; access network signalling; trunk network signalling; broadband modems; internet service providers. Multimedia data representation and compression. Error detection methods. Forward error control. The World Wide Web: introduction; overview; URLs and HTTP; HTML; Java and JavaScript; audio and video; wireless web; web operation.

Digital Systems I

The decimal, binary and hexadecimal number systems. The BCD system. Conversion between systems. Alphanumeric binary codes. Parity. Gray code. Basic logic functions. The AND, OR and NOT. The NAND, NOR XOR and XNOR. The universality of NAND and NOR. Dual symbols. Simplification using Boolean algebra. Simplification using the Karnaugh map. Combinational logic circuits. Functions of combinational logic, Adders, Comparators,

Decoders, Encoders, Code converters, Multiplexers and Demultiplexers. Sequential logic circuits. Latches and Flip-Flops. Shift registers. Counters.

Digital Systems 2

Sequential logic circuits. JK and D flip flops and latches, operation, applications, timing diagrams, counters, shift registers, serial/parallel data transfer, sequence tables, as table and monostable multivibrators. Interfacing and data converters. Interface busses, digital to analog and analog to digital converters, parameters and performance issues. Memory devices. Data and Programme memory devices. Flash memories. Application in microcomputers. Integrated circuit technologies. Displays. Multiplexing.

Digital Systems 3

Introduction to microprocessors & microcontrollers. Concepts of programme storage and programme processing. Basic assembly language programming & machine coding. Function of the CPU, memory and ports. Microcontroller architecture. Steps in programme development and testing. Microcontroller circuit design. Microcontroller interfacing. Software and hardware timing techniques. Interrupts. Display multiplexing. Analogue to Digital conversion. Keypad interfacing. Comparison of microcontrollers.

Electrical Engineering 1

Introduction to electrical and mechanical engineering quantities and the application thereof, batteries, direct current theory and network analysis, alternating current theory and measurements, electromagnetism, magnetic circuits, inductance and capacitance.

Electrical Engineering 2

Alternating current networks, parallel and series resonance, direct and alternating current circuit analysis, power factor correction, harmonics, three phase circuits.

Electronic Communication 2

Introduction to communications engineering. Fourier series analysis. The spectrum. Frequency response of RLC circuits. The dB. Noise analysis, Noise Ratio and Noise Figure. Analogue modulation, AM, FM and PM. The radio receiver and the radio transmitter. Basic antennas and propagation. The radio link budget.

Electronics I

Semiconductor basics. N type and P type materials, depletion region, and barrier potential. The diode. Ideal, practical and complete diode models. IV characteristics. Packages and terminal identification, data sheet and testing of diodes. Application and design as rectifier circuits in power supplies and as clippers and clampers. Troubleshooting power supplies and diode circuits. Zener diode characteristic. Basic Zener regulator circuit. The Transistor. Structure, basic operation as an amplifier and as a switch. Characteristic curves and parameters. DC load line and operating point. Package types and terminal identification. Testing of transistors. Transistor bias circuit analysis and design. Troubleshooting various faults in transistor circuits. Operational amplifiers, symbol, terminals and package types. The ideal and practical op- amp. Op-amp modes, single ended input and differential input operation. Bias current and offset voltage compensation. Negative feedback. Analysis of the non-inverting, inverting and voltage follower

configurations.

Electronics 2

Power supply filters and regulators including series, shunt and integrated voltage regulators. Zener diodes and Zener diode applications. Frequency response including basic concepts, the decibel, filters and plotting filter response. Op-Amps and Comparators-explanation of circuits, operation, derivations of relevant equations, sketch of circuit waveforms. Amplifiers (small signal analysis). Multistage amplifiers. Field Effect transistors including ac and dc analysis. Power Control devices including SCR, diac, triac and UJT. Use of characteristic curves to explain operation of the device and its applications. Power Amplifiers. The different classes (A, B, AB, C) including biasing of devices, efficiency and advantages or disadvantages.

Electronics 3

Amplifier theory and application: direct coupled amplifiers; direct-coupled differential amplifiers, differential and common mode signals and gains, CMRR; current-source biasing, current mirrors, active loads. integrated amplifiers: op-amp applications; performance limitations of real op-amps; oscillators: IC relaxation oscillators: comparators and Schmitt triggers; a stable circuit; sinusoidal oscillators: positive feedback, Barkhausen criterion Wein-bridge and phase-shift circuits; voltage regulators: feedback voltage regulators, switching regulators and IC regulators; power transistors and heatsinking; passive filter design: passive RC filters; transfer characteristic analysis, limitations; filter performance criteria; filter types: Butterworth, Chebyshev and Bessel; simple passive filter design; noise: measurement and interference; and noise bandwidth limitation.

Logic Design 3

Introduction to PLDs. PLD types, uses and internal configurations. Performance issues. Implementation of a wide range of logic functions and logic devices using industry-standard PLDs. Programming, simulation and real-time prototype testing. Complete design of a digital project including background information, block diagrams, circuit design, testing and troubleshooting, recording resultant data and project presentation

Mathematics 1

Determinants, logarithms, formulae, trigonometry, radian measure, complex numbers, statistics, differentiation, elementary integration.

Mathematics 2

Differentiation, integration and first order differential equations with applications, matrices.

Mathematics 3

The solution of ODEs by D-operators, Laplace transforms, numerical techniques. Eigenvalues and eigenvectors, Fourier series.

Microprocessors 3

Interpreting and understanding the architecture of a microprocessor system, programming a microprocessor system to perform small functions and applying microprocessor software design

tools and techniques.

Microwave Communication 3

Mismatched transmission lines, VSWR, Reflection Coefficient and Return Loss, The Smith Chart, Microstrip. Lumped element components at high frequencies, Lumped and distributed element impedance matching networks. Network characterization using Y and S parameters, power gains associated with a 2 port network, the Vector Network Analyser. Narrowband amplifier design, stability, design for maximum available gain, design with potentially unstable active devices. Thermal noise, noise figure, cascaded noise figure, equivalent noise temperature, C/N and G/T ratio, measurement of noise figure, low noise amplifier design.

Network Systems 2

The module explores the key topics in the field of data and computer communications, pertaining to the Network Layer, in the following general categories: Local Area Networks and Intranets. Wireless Networks. The Internet Protocol. Security. Radio Propagation and Transmission Basics.

Network Systems 3

The module explores the key topics in the field of data and computer communications in the following general categories: Transport Layer: Address/Name resolution, Addressing methods, Segment development, Connection services, End-to-end flow control. Application Layer: Dialog control, Session administration, Translation and Encryption, Service advertisement and Service use Methods.

Operating Systems 3

Introduction to Operating Systems. Discover the concepts, structure and mechanisms of Operating Systems. Beginning with the management of main memory and moving on to processors, devices, files and networks. Evaluate and research the nature and characteristics of modern operating systems. Compare key areas of Operating Systems design and relate contemporary issues to future directions in the Development of Operating Systems including Open Source Software and Open Standards.

Process Instrumentation 2a

Introduction to instrumentation engineering terminology and definitions. Introduction to radioactivity and radiation measuring devices. Basic pressure measurement terminology, units and references (types). Pressure measuring devices. Level measurement methods. Temperature measurements: Contact and non-contact methods. Introduction to flow measurements. Process instrumentation engineering documentation: Symbols / logic symbols / tag numbering and loop diagrams.

Process Instrumentation 2b

Process control basics (On/Off control and PID control), Flow introduction, Bernoulli's theorem. Flow measuring devices (restriction devices, velocity detectors, mass flow detectors and volume flow detectors), Flow calculations (liquid flow and steam flow), Valves, Actuators (pneumatic and electric), Positioners, Pumps, Telemetry (analogue and digital), Instrument documentation (P&ID and loop diagrams).

Process Instrumentation 3

Unit operations: Boilers, distillation columns, heat exchangers, refrigeration systems. Control Systems: Discrete hardware, interface considerations, PLC, DCS. Control Strategies: Feedback, feed forward, decoupling, cascade, ratio. Analysers: Sampling, chromatographs, oxygen, pH, conductivity. Machine Control: Encoders, proximity devices, current, shaft speed, drives. Instrumentation Engineering: Hazardous environments, air supplies, electrical supplies, signal wiring practice.

Programming 1

An introduction to basic programming techniques. Problem solving techniques eg algorithms, flowcharting, tracing. Introduction to g++ for Linux. Use of complex programming structures such as control structures, arrays and functions. Programming of hardware devices via the parallel port.

Programming 2

Application development in C/C++ using the Object-Oriented programming paradigm (composition, inheritance and polymorphism). Reading from and writing to text and binary files. String manipulation using character arrays and string objects. The use of pointers to enhance programme efficiency. Reading data from and sending data to the parallel port. Introduction to STL (Standard Template Library) and the graphics library.

Programming 3

Internet Programming using JavaScript for interactive Web pages. Data and control structures using JavaScript. An introduction to Query language to implement database access through Web pages.

Projects 1

Planning and construction of a project. Computer aided drawing. Ergonomic and aesthetic design principles. Safety. Workshop tools and machines. Sheet metal work. Materials technology. Connections. Printed circuit boards. Soldering.

Projects 2

Design, planning, construction, and testing of a project. Design specifications and data sheets. Component failure and reliability. PCB silk screening, thru-hole plating and thick film technology. Single- and double-sided PCB track layout and board manufacture methods.

Radio Engineering 3

Phase-locked loops and RF applications, frequency synthesis, Fourier series and Fourier transform in the context of digital modulation, Shannon-Hartley theorem, Shannon limit, pulse shaping, typical pulse formats, power in digital signals, sampling, DACs, ADCs, multiplexed PCM, dynamic range, quantisation noise, commanding, codecs, OOK, BPSK, quadrature modulator, quadrature demodulator, m-PSK, DQPSK, $\pi/4$ -DQPSK, BFSK, MSK, GMSK, m-QAM, ASCII, error detection and correction, convolutional codes, CRC, noise and error rate, serial interface standards.

Software Design 2

General software design utilising the top-down design method. The VB6 IDE. Event-driven programming. Designing a GUI. Variables, arrays, and the scope of variables. Relational expressions. Control structures. Loop structures. Timers. Line drawing. Sequential file access. Serial communications. Data acquisition and analysis. Electronic Communications option: EXCEL applications including Fourier series, Fourier transforms, FFT, Macros and VBA programming. Process Instrumentation and Control option: General PLC operation. Inputs and outputs. Latching circuits. Timers. Counters. Ladder logic. Statement list. Function block.

Software Engineering 3

System development life cycle models. The five stages of software process. Testing, requirements phase, analysis phase, object orientated analysis, design phase, implementation. Post-delivery maintenance. Planning the software process.

Systems Analysis 2

Introduction to concepts, principles, and stages of computer-based information systems analysis. Systems development and the different methods, tools, and techniques used in systems analysis and design. Feasibility study, requirements for definition design and development of documentation. The system development life cycle, prototyping, data modelling, and user involvement. The objective of the course is to learn and demonstrate an understanding of systems analysis principles, concepts, and evaluation and to gain an appreciation for the scope of systems analysis in a business organization context.

BACCALAUREUS TECHNOLOGIAE DEGREE: ENGINEERING: ELECTRICAL (LIGHT CURRENT)

NOTE: As gazetted in the Government Gazette, Vol. 613, No. 40123, 06 July 2016, the last date for first time entering students enrolling in academic programmes that are not aligned with the Higher Education Qualifications Sub-Framework is the 31st December 2019. No person will be able to enrol for a Bachelor of Technology (BTech Degree) at DUT, or at any other Institution in South Africa after this date.

BTI GENERAL INFORMATION

This Baccalaureus Technologiae Degree: Engineering: Electrical (Light Current) qualification is intended to broaden and deepen the knowledge base acquired in the National Diplomas in Electronic Engineering and Computer Systems, and to consolidate concepts and theories through substantive experimental and design projects. This qualification is intended for electronic engineering technicians working in the instrumentation, control and communications related industries.

The engineering profession contributes to the technical, social, economic and environmental infrastructure of the country, leading to socio-economic growth. A framework of engineering qualifications develops the human resources essential for sustaining the profession. Within that framework, this qualification is designed for the development of engineering technologists to enhance a student's knowledge within a specialized discipline. At present the fields of Instrumentation and Control, Electronic Communications and Computer Systems are offered. In all these fields, an emphasis is placed on the need to be professional and to function at the level of a Technologist.

A graduate with this qualification will be able to: -

1. Apply engineering principles to systematically diagnose and solve ill-defined problems in an engineering environment within a chosen field of specialization.
2. Communicate technical, supervisory and general management information effectively.
3. Apply management principles and concepts to manage projects and/or operations within an engineering environment.
4. Conduct and manage a research/development project.
5. Exercise independent technological judgment and responsible decision making by considering the relevant financial, economic, commercial, social, environmental and statutory factors.

The qualified person will be able to register with the Engineering Council of South Africa (ECSA) as a Candidate Engineering Technologist in the field of Electrical Engineering.

BT2 MINIMUM ADMISSION REQUIREMENTS

- (1) National Diploma: Engineering: Electrical (Light Current) OR
National Diploma: Engineering: Computer Systems
- (2) Credits must be obtained for all prerequisite modules as listed in the relevant field of study *prior* to first time registration for the degree.

Note: The last opportunity for first time registration for the BTech degree will be July 2019.

BT3 DURATION OF STUDIES

- (1) The minimum duration of academic studies at the Durban University of Technology shall be two semesters (1 year), unless credits for studies at another institution have been granted.
- (2) For the Industrial Project 4, the minimum duration of registration shall be one semester and the **maximum** duration of registration shall be three consecutive semesters.

Note: Industrial Project 4 is a capstone component of the qualification. If a student has not completed all the requirements for this module within **three consecutive** semesters, then this will be regarded as failure of the project and module. The student will be required to start the process over from first registration with a completely new project and/or supervisor. The student will again be required to pay the full registration fee for the module.

- (3) A student may not register for Industrial Project 4 until written approval of the proposed project has been obtained from a committee comprised of academic staff from the relevant field of study.
- (4) **Students registering for Industrial Project 4 must have passed a minimum of four (4) BTech modules.**

BT4 AWARD OF DEGREE

- (1) The degree will only be awarded where a student has successfully completed the requisite number of modules, as listed in the relevant field of study. The degree will be awarded after a minimum period of one year.
- (2) All modules, as listed under the relevant field of study, are to be completed at DUT unless *prior* written permission is granted by the HOD for the student to register at an alternative institution.
- (3) Degrees are not automatically awarded to candidates who have satisfied all the requirements for each instructional programme. The onus is on the student to apply to the University for the Award of the Degree. In this regard the candidate should obtain the necessary forms from the Secretary of the Department.

BT5 UNSATISFACTORY ACADEMIC PROGRESS

A student who does not obtain a credit for a module after having twice been registered for that module will not be allowed to re-register for that module. A student wishing to appeal against this rule may apply to the Department. Re-registration may be granted at the discretion of the Appeals Committee.

BT6 SEMESTER MARK

- (1) For all examinable modules the semester mark is set at 40% of the final mark.
- (2) A student who for any reason is absent from a particular test, assessment, or scheduled laboratory period, must provide acceptable proof of their reason for absence to the lecturer concerned within two days after returning to classes. Failure to provide proof of acceptable reasons for absence, or failure to undergo a specified alternative assessment, shall result in a zero mark for that test/assessment.

BT7 METHOD OF ASSESSMENT

Modules are evaluated through a *minimum* of two class tests of one-hour duration each, one three-hour examination and a practical/assignment mark. Those modules marked with # are evaluated through a process of continuous assessment. Further details of the method of assessment are included in the module study guide.

BT8 SUB-MINIMUM

- (1) A sub-minimum of 50% will apply to the practical component of all semester marks.
- (2) A sub-minimum of 40% will apply to all semester marks.
- (3) A sub-minimum of 40% will apply to all written examinations.

BT9 SUPPLEMENTARY EXAMINATIONS

- (1) Supplementary examinations are offered for all *examinable* modules. Students who have failed an examinable module qualify for the supplementary examination if they have obtained a final mark (semester mark and examination mark) of at least 45%. A semester mark is only valid for one examination and one supplementary session.
- (2) A final examination is not written in modules evaluated through continuous assessment and if the required pass mark is not attained the module must be repeated.

BT10 FIELDS OF STUDY

The department offers three fields of study in the Baccalaureus Technologiae (B-Tech) Degree in Electrical Engineering (Light Current); these are:

- (1) B-Tech: Engineering: Electrical (LC): Instrumentation and Control (BTEINI)
- (2) B-Tech: Engineering: Electrical (LC): Electronic Communications (BTECMI)
- (3) B-Tech: Engineering: Electrical (LC): Computer Systems (BTECSI)

BT I I PROGRAMME STRUCTURE

There are 5 common core modules in the B-Tech qualifications at DUT; these are:

MODULES	PREREQUISITES	Semester offered (subject to change)	Module Codes	Last Possible Semester of Registration
Engineering Mathematics 4 #	Mathematics 3	1 and 2	EMTH402	July 2021
Digital Signal Processing 4	Engineering Mathematics 4	1 and 2	DSPR401	July 2021
Microcontroller Systems 4	Digital Systems 3	1 and 2	MCSY401	July 2021
Engineering Management 4	None	1 and 2	EMGT402	July 2021
Industrial Project *	Design Project 3	1 and 2	IPRJ401 (1 ST Reg) IPRJ411 (2 nd Reg) IPRJ421 (3 rd Reg)	July 2021 January 2022 July 2022

Denotes that a final written exam is included in the assessment (as opposed to continuous assessment)

* Students registering for Industrial Project 4 must please take note of Rule BT2 (3)

In addition to above **core** modules, students are required to complete at least 3 modules from the following cohort of offerings, depending on their choice of specialisation and required prerequisites.

(1) B-Tech: Engineering: Electrical (LC): Electronic Communications

MODULES	PREREQUISITES	Semester offered (subject to change)	Module Codes	Last Possible Semester of Registration
Electronic Comm. Systems 4	None	1 Only	ECMS401	January 2021
Microwave Engineering 4	Microwave Comm. 3	1 Only	MCWE 401	January 2021
Electronic Communications 4	Engineering Mathematics 4	2 Only	ECOM 402	July 2021
Circuit Analysis 4 # *	None	1 Only	CRTA401	January 2021

Denotes that a final written exam is included in the assessment (as opposed to continuous assessment)

* Students can only register with prior approval from the HOD

(2) B-Tech: Engineering: Electrical (LC): Instrumentation and Control

MODULES	PREREQUISITES	Semester offered (subject to change)	Module Codes	Last Possible Semester of Registration
Process Control 4	Process Instrumentation 3	1 Only	PRCT401	January 2021
Control Systems 4	Control Systems 3	2 Only	CSYS402	July 2021
Process Instrumentation 4	Process Instrumentation 3	2 Only	PRSI401	July 2021
Circuit Analysis 4 # *	None	1 Only	CRTA401	January 2021

Denotes that a final written exam is included in the assessment (as opposed to continuous assessment)

* Students can only register with prior approval from the HOD

(3) B-Tech: Engineering: Electrical (LC): Computer Systems

MODULES	PREREQUISITES	Semester offered (subject to change)	Module Codes	Last Possible Semester of Registration
Computer Networks 4 #	Network Systems 3	2	CNET402	July 2021
Database Programming 4 #	Database Principles 3	1 Only (once in two years) See note **	DBPR401	January 2021
Software Engineering 4	Software Engineering 3	2 Only (once in two years) See note **	SWEN401	July 2021
Electronic Comm. Systems 4	None	1 Only	ECMS401	January 2021
Electronic Communications 4	Engineering Mathematics 4	2 Only	ECOM 402	July 2021
Circuit Analysis 4 # *	None	1 Only	CRTA401	January 2021

Denotes that a final written exam is included in the assessment (as opposed to continuous assessment)

* Students can only register with prior approval from the HOD

* / ** Database Programming 4 will only be offered in January 2019 and 2021 and Software Engineering 4 will only be offered in July 2020.

BT12 ABRIDGED MODULE CONTENT

Computer Networks 4

Advanced top-down approach of the protocol stack featuring the Internet. Advanced application layer protocols (HTTP, SMTP, FTP, DNS). P2P file sharing. Building a simple Web server (TCP/UDP). Principles of reliable data transfer —Go-Back-N and Selective Repeat algorithms. Principles of Flow Control and Congestion Control. Forwarding and Routing (Distance-Vector/ Link-State algorithms) in the Internet (IPv4 & IPv6). Error-detection and Correction techniques including Parity, Check summing and CRC coding. Wireless and mobile networks including Wi-Fi and Bluetooth.

Control Systems 4

Analysis and design of control systems in the state space. Computational Intelligence. Artificial Neural Networks. Fuzzy Knowledge based systems. Evolutionary Algorithms. Swarm Algorithms.

Database Programming 4

Basic concepts of database systems and advanced database systems. An overview of various theoretical approaches to database management systems and structures. Implementation and use of database systems, setting up of a database using fourth generation languages and database programming. A study of one database system implementation. Database planning, data models, R-R diagrams, database models, code generation packages.

Digital Signal Processing 4

Discrete time DAC Synthesis techniques Elaborate signals complex exponentials ADC and sampling aliasing filtering time invariance, linearity system difference equation impulse response FIR, IIR testing method stability convolution causality DFT programming the DFT FFT LTI systems DTFT use of equaliser reconstruction filters Z-transform poles and zeros pure real system design stability oscillator design gain response phase response linear phase direct form I and II cascade structure.

Electronic Communication Systems 4

Introduction to teletraffic. The Erlang B and C formulas and their use. The public switched telephone network. The local loop. The transmission system, PCM and the PCM frame hierarchy. Signalling. Switching systems, time and space switches. The GSM cellular system. The cellular concept, the air interface, TDMA, FDM and the frame structure. Data communications. The OSI model. LANs, WANs and the internet. Radio wave propagation in the troposphere. Radio refractive index. Link budget calculations for analogue and digital radio links.

Electronic Communications 4

Signal representation, Fourier transforms, transmission through linear systems, convolution, random signals and probability, histograms, probability density functions, Gaussian distribution and the error function. Baseband digital communication, source and channel coding. The effect of noise and inter symbol interference. Forward error correction, block and convolutional codes. Digital modulation, ASK, PSK, FSK, QAM, MSK. Error performance of digital modulated signals, measurements on digital communication systems.

Engineering Management 4

General management, Strategic Management, Market Management, Creativity and Teamwork,

Quality, Production, Process Redesign, Change Management, Motivation, Labour Procedures, Project Management, Time Value of Money, Entrepreneurship, and Financial Accounts.

Engineering Mathematics 4

Linear differential equations, complex analysis, difference equations, linear algebra, z transforms.

Industrial Project 4

A 300-hour industrial design project involving application of advanced principles related to the field of study.

Microcontroller Systems 4

Embedded system, microprocessor, microcontroller, RAM, EPROM, EEPROM, flash memory, ADC, DAC, C programming language, C syntax, compiler, cross-compiler, pre-processor, C pre-processor, in-circuit emulator, debugger, debugging, revision control, SPI, I2C, RS-232, CAN, USB, Ethernet, real-time computing, real-time operating system, embedded Linux, Contiki, semaphore programming, message passing, interrupt, interrupt latency, system-on-a-chip, ASIC, PLD, FPGA, surface-mount technology, RoHS Directive, lead-free solder, electromagnetic interference, practical construction project, practical design, high-level programming and debugging of embedded system.

Microwave Engineering 4

Principles of oscillator design using the loop method and the negative resistance method. LC oscillators, resonator Q factor, augmented resonators. Transmission line resonators, quartz crystal resonators and SAW resonators. Flicker and phase noise, measurement of phase noise. Negative resistance oscillators. An introduction to RF power amplifier design, Linear and non-linear networks, transmission distortion, gain compression, harmonic and intermodulation distortion, cascaded 3rd order intercept. An introduction to class A power amplifier design. Stability, the design of a class A power amplifier.

Process Control 4

PLC Systems: Scan time, power supplies, marshalling, grounding and noise, project management and documentation, software, commissioning, communications, bus systems, IEC 61131. DCS: layout and functions, dependability issues, design. Single loop controllers: Structure, configuration, application. SCADA systems: Structure, implementation, communications issues.

Process Instrumentation 4

Analysers: Selection, application, sampling systems, Stack gas, water quality. Final Control Elements: Control valve sizing and selection, variable speed drive sizing and selection. Control rooms: Lighting, air conditioning, pressurization, fire protection, noise, ergonomics. Unit operations: pH control, reactor control.

Software Systems 4

Graphical applications software as applied to microprocessor systems.

Software Engineering 4

Outline of software development, software development life cycle, planning and estimating, test plan, requirements, properties of good requirements, specifications, software design, coding, wrapping up design and coding, software testing, coverage and systematic testing.